

Operating and mounting manual flow control slide valves MRS Ro We/St/Pn

Contents

- 1.0 General Remarks**
 - 1.1 Valve data
 - 1.2 Application
- 2.0 Danger Notices**
 - 2.1 Safety terms
 - 2.2 Safety notice
 - 2.3 Qualified staff
 - 2.4 Unauthorized modification and spare part production
 - 2.5 Unauthorized operation
 - 2.6 Safety information for the use in explosion-prone areas guideline 2014/34/EU
 - 2.7 Safety information regarding guideline 2014/68/EU attachment I
- 3.0 Handling**
 - 3.1 Transport
 - 3.2 Storage
 - 3.3 Handling before mounting
- 4.0 Product Description**
 - 4.1 Function
 - 4.2 Technical data
 - 4.3 Marking
 - 4.4 Selection of electric actuators and pneumatic rotary actuators
- 5.0 Installation**
 - 5.1 Warning of dangers during installation, operation and maintenance
 - 5.2 Installation
- 6.0 Operation**
 - 6.1 Commissioning
 - 6.2 Shutting down
 - 6.3 Maintenance
 - 6.4 Putting back into operating
- 7.0 Troubleshooting**
 - 7.1 Detection of defects
 - 7.2 Troubleshooting plan
- 8.0 Replace the Flow Control Slide Valves**
 - 8.1 Replacement of wear parts
- 9.0 Warranty**
- 10.0 Explanations on Codes and Directives**
- 11.0 Drawing**
 - 11.1 Sectional drawing
 - 11.2 View drawing
 - 11.3 List of parts
 - 11.4 Dimension
- 12.0 Declaration of Conformity**

1.0 General Remarks

This operating manual includes instructions to assemble and operate the flow control slide valves in the prescribed and safe way.

If any difficulties appear that can not be solved by means of the operation instructions, further information may be demanded from the manufacturer. This operating manual is in accordance with the relevant valid EN safety standards and the valid prescriptions and rules of the Federal Republic of Germany.

If the flow control slide valves are used abroad of the FRG, the operator and/or the person who is responsible for the plant concept must take care that the valid national rules are met.

The manufacturer reserves the right of any technical change and improvement.

The use of these operating instructions assumes the qualification of the user according to paragraph 2.3 "qualified staff". The operating staff must be trained in accordance with the operating instructions. The operating manual must always be available at the location where used.

1.1 Valve data

Manufacturer:

UNI Geräte E. Mangelmann
Elektrotechnische Fabrik GmbH
Holtumsweg 13
D-47652 Weeze
Telefon: +49 (0) 2837/9134-0
Fax: +49 (0) 2837/1444
E-Mail: info@uni-geraete.de
Homepage: www.uni-geraete.de

Designation

Actuators for control without zero obturation

Control base: Type approved EU/2016/426
Prod. ID. Nr. CE-0085-AQ0616, DIN EN 16678

Type of drive: We with free shaft end
Working pressure: 10-MRS Ro We ... 0 – 10bar

Type of drive: St with electrical actuator
Working pressure: 10-MRS Ro St ... 0 – 10bar

Type of drive: Pn with pneumatic actuator
Working pressure: 10-MRS Ro Pn ... 0 – 10bar

Medium and Ambient temperature: -20°C to + 60°C

Fitting position: We arbitrary
St/Pn vertical or horizontal drive

Flange connection measures DN15 – DN50 acc. to DIN EN 1092-2 / ANSI

Flange DN	PN	15 (5N) 1/2"	20 (7N) 3/4"	25 (10N) 1"	32 (12N) 1 1/4"	40 (15N) 1 1/2"	50 (20N) 2"	Test pressure (*) PT
...-MRS Ro We... with free shaft end								
10- MRS Ro We..	16	X	X	X	X	X	X	PN 16

also essential, in order to avoid disturbances that might affect direct or indirect damage to property or injury to persons.

2.2 Safety notice

Non observance of safety instructions can lead to loss of any claim for damages.

Non observance can lead to the following mentioned dangers:

- Failure of important functions of the flow control slide valve and plant
- Endangering of persons by electrical or mechanical influences.
- Protection against accidental contact for moving parts may not be removed as long as the flow control slide valve is in operation.
- Leakage of dangerous media (e.g. explosive, toxic, hot) must be removed in the way that there is no danger for persons or environment. Laws and regulations must be observed.

2.3 Qualified staff

These are persons who are familiar with erection, assembly, starting, operation and maintenance of the product and who have special qualifications acc. to their activities and functions, e.g.:

- Instruction and obligation to carry out and meet all regional and in-house orders and requirements.
- Education or instruction according to the safety engineering standards in use and maintenance of adequate safety and working protection equipment.
- Training in first aid.

2.4 Unauthorized modification and spare part production

Modification or changes of the flow control slide valve are only allowed after agreement of the manufacturer. Original drawings and accessories authorized by the manufacturer are for safety purposes. The use of other parts or unauthorized changes at the flow control slide valve by third persons may cancel and abolish the manufacturer's liability for resulting consequences.

2.5 Unauthorized operation

Operational reliability of the delivered flow control slide valve is only guaranteed in case of determined use in accordance to paragraph 1 of the operating manual. **The application limits mentioned on the type sign may on no account be exceeded.**

2.6 Safety information for the use in explosion-prone areas guideline 2014/34/EU

- The temperature of the medium must not exceed the respective temperature class, and respectively, the respective maximum permitted medium temperature as per operation guidelines.
- If the valve is heated (e.g. heating jacket), care must be taken, that the specified temperature class is kept in the line.
- The valve must be connected to the ground.
In the case most simple this can be realized via pipe screws by means of tooth discs.
Otherwise the connection to the ground must be implemented by other measures e.g. cable links.
- Control valves, electrical and electrical/mechanical drives as well as sensors must undergo a separate conformity check as per ATEX. In doing so the respective safety and explosion protection information in the operation instructions are to taken into special consideration.
- Any modifications whatsoever to the valve are not allowed. The ATEX approval is void with immediate effect if the valve is modified without prior authorisation (even including painting).
- UNI-Geräte GmbH must be consulted before any modifications are made.

Furthermore we point out the Guideline ATEX 118a, which include the minimum regulations for the improvement of the health-related situation and the safety of the employees, who might be jeopardized by an explosive atmosphere.

2.7 Safety information regarding guideline 2014/68/EU attachment I



Danger!

UNI valves are not an accessory with a safety function as defined in the PED 2014/68 / EU Article 2 (4) and Article 4 (1) (d) by category IV
Use or classify!

3.0 Handling

3.1 Transport

For any transport works, the generally recognised technical rules and standards as well as rules for prevention of accidents must be observed.

During transport, storage and decommissioning, protective caps must be attached to the sides of the valve.

The goods to be transported must be carefully treated. During transport, the valve must be protected against strokes, impacts or vibration. The coat of lacquer may not be damaged. Transport temperature is -20°C up to $+60^{\circ}\text{C}$.

Never transport the flow control slide valve on cable glands, equipment plugs or attachments.
Transport the flow control slide valve on the flange bores or with a belt underneath the actuating drive.
(See illustration).



Transport the flow control slide valves in a case or on a pallet with smooth base and put it softly on plain floor.

The goods must be checked on completeness and transport damage. See also section 9.0

3.2 Storage

If the flow control slide valve is not installed immediately after delivery, it must be stored properly.

- Storage temperature -20°C up to $+60^{\circ}\text{C}$, dry and clean.
- The lacquering protects against corrosion in neutral dry atmosphere. Do not damage colour.
- In humid rooms, a drying agent or a heating resp. is necessary because of condensation of water.

Requirements according to DIN 7716 (products made of caoutchouc and rubber) must be met.

3.3 Handling before mounting

- Protect against atmospheric influences such as humidity.
- Appropriate treatment protects against damage.

4.0 Product Description

The UNI-Geräte MRS flow control slide valve is a device for controlling with zero obturation with a linear control characteristic (rangeability 20:1).

The valves have a leakage of 0.03% of the K_v value.

The minimal main volume is 20% of the K_v value.

Sectional drawing 11.1 Fig. 1, 2 and 3 shows the valve construction.

4.1 Function

The flow control slide valve works according to the ball cock principle. Control and throttling of the medium is achieved manually via the volume control spindle (245) (setting 0° - 90°) or by an electrical or pneumatic actuator.

The flow control slide valve can be set to a defined main volume (flow rate 20% - 100%), see section 4.1.1

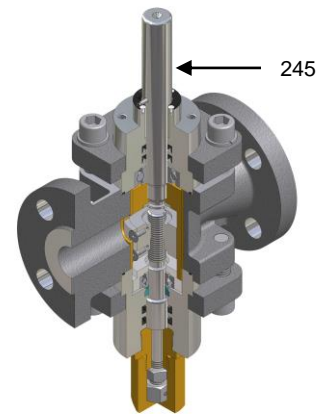

4.1.1 Setting the main volume

The main volume is set manually.

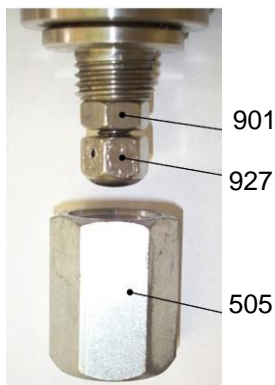

1. Slacken and remove the protective cap (505).
2. Undo the hexagon lock nut (901).
3. By turning the cap nut (927) clockwise as far as the stop the main volume is reduced to 0%.
4. The characteristic of the flow rate can be gathered from the table below.
5. Turn the cap nut (927) counter-clockwise to adjust by the number of turns (dependent on type and main volume %)
6. Tighten the hexagon lock nut (901)
7. Screw on and tighten the protective cap (505)

4.1.2 Table for main volume

Type		Main volume in %				
		20%	40%	60%	80%	100%
..-MRS 5N (DN 15)	Turns	1	2	3	4	5
..-MRS 7N (DN 20)	Turns	1	2	3	4	5
..-MRS 10N (DN 25)	Turns	2,5	5	7,5	10	12,5
..-MRS 12N (DN 32)	Turns	3	6	9	12	15
..-MRS 15N (DN 40)	Turns	3,5	7	10,5	14	17,5
..-MRS 20N (DN 50)	Turns	5	10	15	20	25
..-MRS 25N (DN 65)	Turns	6	12	18	24	30
..-MRS 30N (DN 80)	Turns	7	14	21	28	34
..-MRS 100 (DN 100)	Turns	8	16	24	32	40
..-MRS 125 (DN 125)	Turns	10	20	30	40	50
..-MRS 150 (DN 150)	Turns	12	24	36	48	60
..-MRS 200 (DN 200)	Turns	9	18	27	36	45

4.2 Technical data

4.2.1 Electrical actuator (St)



Actuator incl. Console

Type	Torque Nm	Actuating time*				Voltage*			Positioner	
		30(25) s/90°	50(42) s/90°	60(50) s/90°	65 s/90°	230 VAC	115 VAC	24 VDC	ESR..	PMR..
NK 6010	10	-	X	X	-	X	X	-	-NK	-NK
NK 6015	15	-	X	X	-	X	X	-	-NK	-NK
NK DC3010	10	X	-	-	-	-	-	X	-NK	-
NL 3020	20	X	-	-	-	X	X	-	-NL	2-LC
NL 6020	20	-	-	X	-	X	X	-	-NL	2-LC
NL 3040	40	X	-	-	-	X	X	-	-NL	2-LC
NL 6040	40	-	-	X	-	X	X	-	-NL	2-LC
N 1	15	-	-	X	-	X	X	X	-N	PMR 3
N1 DC	16					-	-	X	-N	-
N 2A	21	X	-	X	-	X	X	X		PMR 3
N 3	35	X	-	X	-	X	X	X		PMR 3
N 4A	60	-	-	X	-	X	X	X		PMR 3
N 5A	80	X	X	-	-	X	X	X		PMR 3
N 5	110	X	X	-	-	X	X	X		PMR 3
NE 1	15	-	-	-	X	X	X	X		PMR #
NE 2	60	-	-	-	X	X	X	X		PMR #

* Other actuating times and voltages upon request

External mounting

4.2.1 Pneumatic rotary actuator (Pn)



Rotary actuator, single-acting incl. console

Type	PGF07	PGF10	PGF15	PGF20	PGF25	PGF30	PGF33	PGF 35
Torque Nm	6	10	22	30	60	90	160	210
Control pressure	5 – 10bar							

4.3 Marking

The type sign on the solenoid drive has the following information:

- Fabricator
- Valve type, nominal width, pressure and temperature indication, fitting position
- Year of construction/ production no.
- Product ID No. to EU/2016/426
- Valve class and valve group acc. to DIN EN 16678
- CE-sign and no. of relevant location to 2014/68/EU
- Fluid group and test pressure PT to 2014/68/EU

Refer also to section 10.0.

4.4 Selection of electric actuators and pneumatic rotary actuators

In operation, the maximum permissible differential pressure ($p_e - p_a$) must not be exceeded. The limits can be obtained from the diagram.

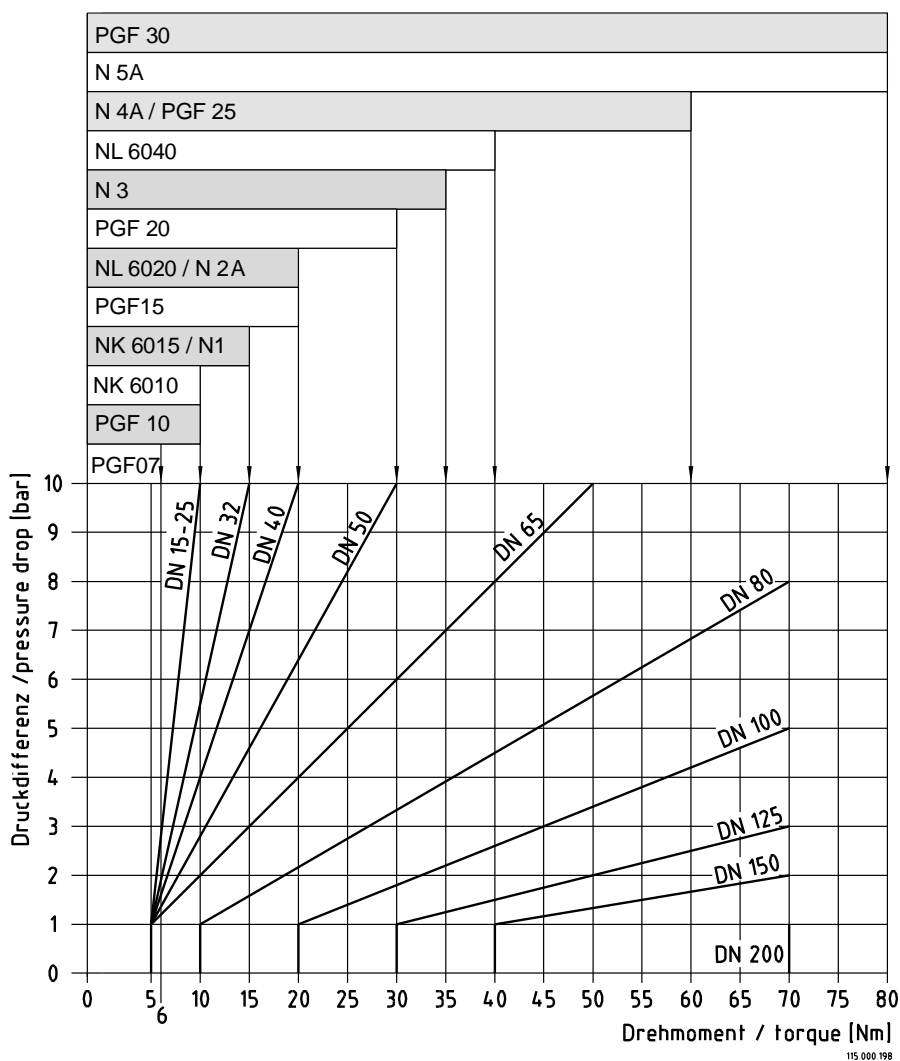

Example:	
Input pressure	$p_e = 7 \text{ bar}$
Output pressure	$p_a = 4 \text{ bar}$
Nominal width	DN 65

Solution:	
Pressure difference	$7 \text{ bar} - 4 \text{ bar} = 3 \text{ bar}$
Torque	$= 15 \text{ Nm}$

Selected electric actuator NK6015 or higher
Selected pneumatic rotary actuator PGF 15 or higher

5.0 Installation

5.1 Warning of dangers during installation, operation and maintenance



DANGER!

Safe operation of the flow control slide valve can only be guaranteed if it is installed, commissioned and maintained by qualified personnel (see point 2.3 “Qualified staff”) correctly and in observance of the warnings in this operating manual. Apart from that, the operation safety order and the qualified use of tools and protection equipment must be guaranteed. The operating instructions for the flow control slide valve must be observed during all work on or with the flow control slide valve. Failure to observe these instructions may result in injury or in damage to the flow control slide valve or other installations.

5.2 Installation

Apart from the general installation guidelines, the following points should be observed:



NOTICE!

- The fitting position for flow control slide valves (We) is arbitrary.
- The fitting position for flow control slide valves (St/Pn) are vertical or horizontal drive.
- The inside of the valve and the pipeline must be free from foreign particles.
- Centre gaskets between the flanges.
- The connecting flanges must be aligned.
- Ensure that none of the components is strained during installation.
- The flow control slide valve must not be used as a fixed point; it is supported by the pipework system.
- Protect flow control slide valve from soiling, particularly during construction work.
- Thermal expansion of the pipework must be equalized using compensators.

6.0 Operation



DANGER!

Before commissioning a new installation or before starting up an installation again after repairs or modifications, ensure:

- The proper completion of all installation and assembly work!
- Commissioning only by “qualified staff” (see point 2.3).
- Installation or repair of existing guards and protection equipment.

6.1 Commissioning

- Before commissioning, check the data on material, pressure, temperature and flow direction with the layout plan of the pipework system.
- Depending on the field of application, the local regulations have to be observed, e.g. the operation safety order.
- Leakage inspection of the installed flow control slide valve.

6.2 Shutting down

- Depending on the field of application, the local regulations have to be observed, e.g. the operation safety order.

6.3 Maintenance

Flow control slide valves have to be checked at regular intervals for proper function and internal leak tightness. The intervals for regular inspections have to be defined by the operator according to the operating conditions. UNI-Geräte recommends an internal visual inspection once a year.

6.4 Putting back into operation

When putting a flow control slide valves back into operation, ensure that all the necessary steps described in section 5.2 (Installation) and section 6.1 (Commissioning) are repeated.

Repair or maintenance works at the manufacturing company (UNI- Geräte)



DANGER!

Valves and fittings must be delivered clean and free from substances which are harmful to health or to the environment.

7.0 Troubleshooting

7.1 Detection of defects



DANGER!

Be sure to observe the safety instructions during troubleshooting.

If the malfunctions cannot be remedied using the following **“Troubleshooting plan (7.2)”** please contact the manufacturer.

In the event of faults in the function or operating behaviour of the valve, check whether the installation work was carried out and completed as described in this operating manual.

Depending on the field of application, the operation safety order must be observed.

Check the data on material, pressure, temperature, voltage and flow direction with the layout plan of the pipework system. In addition, check whether the operating conditions correspond to the technical data in the data sheet or on the rating plate.

7.2 Troubleshooting plan

Malfunction	Possible causes	Remedy
MRS Ro We		
no flow, or respectively low flow	The main volume is turned to 0%	Set main volume according to section 4.1.2
	Blockage in the pipeline system Foreign body in the pipeline	Check the pipeline Clean the pipeline
	Operating pressure too high	Compare the operating pressure against the data on the type plate
	Flange covers were not removed	Remove the flange covers
No outer seal-tightness	Seals are damaged	See section 8, Replacing the sealing elements (spare parts kit)
Opening and closing operation	Flow control slide valve opens and closes sluggishly	See section 8, Replacing the grooved ball bearing (spare parts kit)
MRS Ro St (additionally)		
no flow, or respectively low flow	Actuator does not open or close	Switch on actuator, check voltage
	Positioner is not working	Check positioner voltage, replace
	Incorrect programming	Use manufacturer's original documentation
	Poor limit switch adjustment	Check the adjustment
MRS Ro Pn (additionally)		
Opening and closing operation	Rotary actuator does not open or close	Switch on control valve for rotary actuator
	Control valve is not working	Check voltage, replace
	Positioner is not working	Check the pressure connection, check connection to rotary actuator, replace
	Incorrect programming	Use manufacturer's original documentation



NOTICE!

Observe section 9.0 before all installation and repair work!

Observe section 6.4 when putting the valve back into operation!

8.0 Replace the Flow Control Slide Valve

In addition to the general installation guidelines and the operation safety order, the following points must also be observed:



DANGER!

- Depressurised pipework system
- Cooled medium
- Emptied installation
- Vent pipework systems containing corrosive, inflammable, aggressive or toxic media
- Have dismantling work carried out only by qualified staff (see point 2.3)

8.1 Replacing the wearing parts

Take the flow control slide valve (MRS Ro St) (MRS Ro Pn) out of service as described in section 6.2.

The spare parts kit is to be used if there is any damage to the sealing elements or the grooved ball bearing.

Fig.1 ..-MRS Ro We... DN15 – DN100

Slacken the cylinder head screws (910/2 with DN15 – DN50) or hexagon screws (900/2 with DN65 – DN80) with lock washers (905) and remove them from the valve chamber (100).

Take down the housing flange (108/2) from the sealing piece (226/2).

Take out the entire inner part (226/2, 237, 238, 255, 244, 212/1, 212/2, 302/2, 403/2, 403/3, 404/2, 405, 505, 901/1, 901/2, 943/2) from the valve chamber (100).

Unscrew the protective cap (505) of the spindle guide (212/2).

Slacken the hexagon nut (901/2). By turning the hexagon nut (901/1) clockwise, the volume adjusting cylinder (237) with guard (238) can be screwed downward by the volume adjusting spindle (244).

Unscrew spindle guide (212/2) from spindle guide (212/1) and remove with the volume adjusting spindle (244).



NOTE!

The disk MRS (240/2) and grooved ball bearing (302/2) between guide piece (255) and sealing piece (226/2) may fall out.

Unscrew the spindle guide (212/1) from the sealing piece (226/2).



CAUTION!

Knock out the dowel pin (943/1) and cleanly deburr the bore.

Reason: Burr in the bore of the volume control spindle (245) could ruin the lip ring (404/1) when assembling and therefore external seal-tightness can no longer be guaranteed.

Slacken the cylinder head screws (910/1 with DN15 – DN50) or hexagon screws (900/1 with DN65 – DN80) with lock washers (905) and remove them from the valve chamber (100).

Take down the housing flange (108/1) from the sealing piece (226/1).

Take out the entire inner part (226/1, 239, 240/1, 245, 302/1, 403/1, 404/1, 940, 966, 973) from the valve chamber (100).

Detach the sealing piece (226/1) from the control cylinder (239) with the volume control spindle (245).



NOTES!

The disk MRS (240/1) and grooved ball bearing (302/2) may fall out.

The lip ring (404/1) contained in the sealing piece (226/1), the o- ring (403/1) and the grooved ball bearing (302/1) must be replaced during the overhaul.



NOTE!

The renewable parts in the spare parts kit must be fitted when overhauling

Fig.2 ..-MRS Ro We... DN125 – DN150



CAUTION!

Knock out the dowel pin (943/1) and cleanly deburr the bore.

Reason: Burr in the bore of the volume control spindle (245) could ruin the lip ring (404/1) when dismantling/assembling and therefore external seal-tightness can no longer be guaranteed.

Unscrew and remove the spindle guide (212/2) from the sealing piece (226/1).

Slacken the hexagon screws (900/1 with DN100) or cylinder head screws (910/1 with DN125 – DN150) with lock washers (905) and remove them from the valve chamber (100).

Take down the housing flange (108/1) from the sealing piece (226/1). Remove the sealing piece (226/1) from the valve chamber (100) and lay it on a clean surface.



NOTE!

The disk MRS (240/1) and grooved ball bearing (302/1) between the control cylinder (239) and the sealing piece (226/1) may fall out.

Unscrew the protective cap (505) of the spindle guide (212/2).

Slacken the hexagon nut (901/2).

By turning the hexagon nut (901/1) clockwise, the volume adjusting cylinder (237) with guard (238) moves from the volume adjusting spindle (244) and thereafter the volume control spindle (245) with the control cylinder (239) move upwards out of the valve chamber (100).



CAUTION!

Risk of injury!

The volume adjusting cylinder (237) with guard (238) is loose in the control cylinder (239).

Withdraw the volume control spindle (245) with the control cylinder (239) and the inlying volume adjusting cylinder (237) with guard (238) upwards out of the valve chamber (100) and lay on a clean surface.

Slacken the hexagon screws (900/2 with DN100) or cylinder head screws (910/2 with DN125 – DN150) with lock washers (905) and remove them from the valve chamber (100).

Take down the housing flange (108/2) from the sealing piece (226/2). Remove the sealing piece (226/2) from the valve chamber (100).

Unscrew the spindle guide (212/1) from the sealing piece (226/2).

Remove the guide piece (255) with grooved ball bearing (302/2) and disk MRS (240/2) from the sealing piece (226/2).



NOTE!

Knock out the dowel pin (943/2) from the hexagon nut (901/1). Unscrew and remove the hexagon nut (901/1 and 901/2) from the volume adjusting spindle (244).

Pull out and remove the volume adjusting spindle (244) from the spindle guide (212/1).

Fig.3 ..-MRS Ro We... DN200



CAUTION!

Knock out the dowel pin (943/1) and cleanly deburr the bore.

Reason: Burr in the bore of the volume control spindle (245) could ruin the lip ring (404/1) when dismantling/assembling and therefore external seal-tightness can no longer be guaranteed.

Undo the hexagon nuts (901/4) and remove along with the lock washers (905). Remove the hexagon screws (900/1) from the valve chamber (100).

Detach the sealing piece (226/1) from the valve chamber (100).

Unscrew the protective cap (505) of the spindle guide (212/1).

Slacken the hexagon nut (901/2).

By turning the hexagon nut (901/1) clockwise, the volume adjusting cylinder (237) with adjusting spring (997) moves from the volume adjusting spindle (244) and thereafter the volume control spindle (245) with the control cylinder (239) move upwards out of the valve chamber (100).



CAUTION!

Risk of injury!

The volume control cylinder (237) with adjusting spring (997) is loose in the control cylinder (239).

Withdraw the volume control spindle (245) with the control cylinder (239) and the inlying volume adjusting cylinder (237) with adjusting spring (997) upwards out of the valve chamber (100) and lay on a clean surface.

Undo the hexagon nuts (901/3) and remove along with the lock washers (905). Remove the hexagon screws (900/2) from the valve chamber (100).

Take out the entire inner part (108/1, 212/1, 212/2, 244, 302/2, 403/2, 404/2, 901/1, 901/2) from the valve chamber (100).

Take down the guide piece (255) with grooved ball bearing (302/2) from the spindle guide (212/2).



NOTE!

Knock out the dowel pin (943/2) from the hexagon nut (901/1). Unscrew and remove the hexagon nut (901/1 and 901/2) from the volume adjusting spindle (244).

Undo the setscrew (941). Unscrew the spindle guide (212/1) from the spindle guide (212/2).

Pull out and remove the volume adjusting spindle (244) from the spindle guide (212/2).

Unscrew and remove the spindle guide (212/2) from the housing flange (108/1).



NOTE!

The renewable parts in the spare parts kit must be fitted when overhauling.

Assemble the flow control slide valve in the reverse order to disassembling.



CAUTION!

Install the wearing parts properly and do not damage them when assembling.

Subject the valve to an internal seal tightness test according to DIN 3394-1 as well as a functional test.

9.0 Warranty

Scope and period of the warranty is specified in the edition of the “General Terms of Business of the UNI-Geräte E. Mangelmann Elektrotechnische Fabrik GmbH” valid at the time of delivery or else in the purchase agreement.

We warranty that the valve is free from faults in line with the state of the art and for the confirmed field of application.

No warranty claims will be accepted for damage resulting from improper use or failure to observe these operating and installation instructions, the statutory accident prevention regulations, the EN, DIN and VDE standards and other codes and regulations.

Warranty claims will also not be accepted for damage occurring during operation due to operating conditions deviating from those specified in the data sheet or in other agreements.

Justified complaints will be remedied by reworking by us or specialist companies authorised by us. Claims going beyond the scope of the warranty will not be accepted. The customer shall have no right to the supply of a replacement valve.

Maintenance work, installation of parts from other manufacturers, any modifications to the design and natural wear are not covered by the warranty.

Transport damage must be reported not to us but **without delay** to your responsible goods handling company, the railway company or the shipping agent as otherwise all claims for damages against these companies will be voided.

10.0 Explanations on Codes and Directives

The Commission of the European Union has laid down common directives for the free trading of goods within the Union specifying minimum requirements for safety and health protection. The CE symbol confirms that products comply with the EU directives, i.e. in conformity with the relevant, in particular harmonised standards. Regulation EU/2016/426 and Directives 2014/68/EU are of relevance for the gas valve (mechanical part).

Notes on Regulation EU/2016/426(Gas Appliances Regulation, GAR):

The valves have been developed, manufactured and tested in accordance with harmonised standard DIN EN 16678 and comply with the relevant requirements of the Union Regulation EU/2016/426. Unless otherwise stated separately, this has been confirmed by a type test.

Notes on Directive 2014/68/EU (Pressure Equipment Directive, DGRL):

It has been confirmed that the quality assurance in design control, manufacture and final acceptance of the manufacturer, UNI-Geräte E. Mangelmann Elektrotechnische Fabrik GmbH, satisfy the requirements of 2014/68/EU Article 14 Module H. The gas valves comply with the fundamental requirements of Directive 2014/68/EU. Valves in according to Article 1 Paragraph 2,f,v or Article 4 paragraph 3 are not allowed to have the CE Mark in according to Article 18.

Note concerning ex-guideline 2014/34/EU (explosion guideline ATEX):

The product is not subject to guideline 214/34/EU, since due to the loads occurring during practical operation, there is no effective source of ignition even in case of an error case to be assumed. This also applies to spring loaded components in gas-filled rooms. In case of electric drives, sensors or other electric components the application as per 2014/34/EU is to be checked separate

11.0 Drawing

11.1 Fig.1 Sectional drawing DN 15 – DN 100

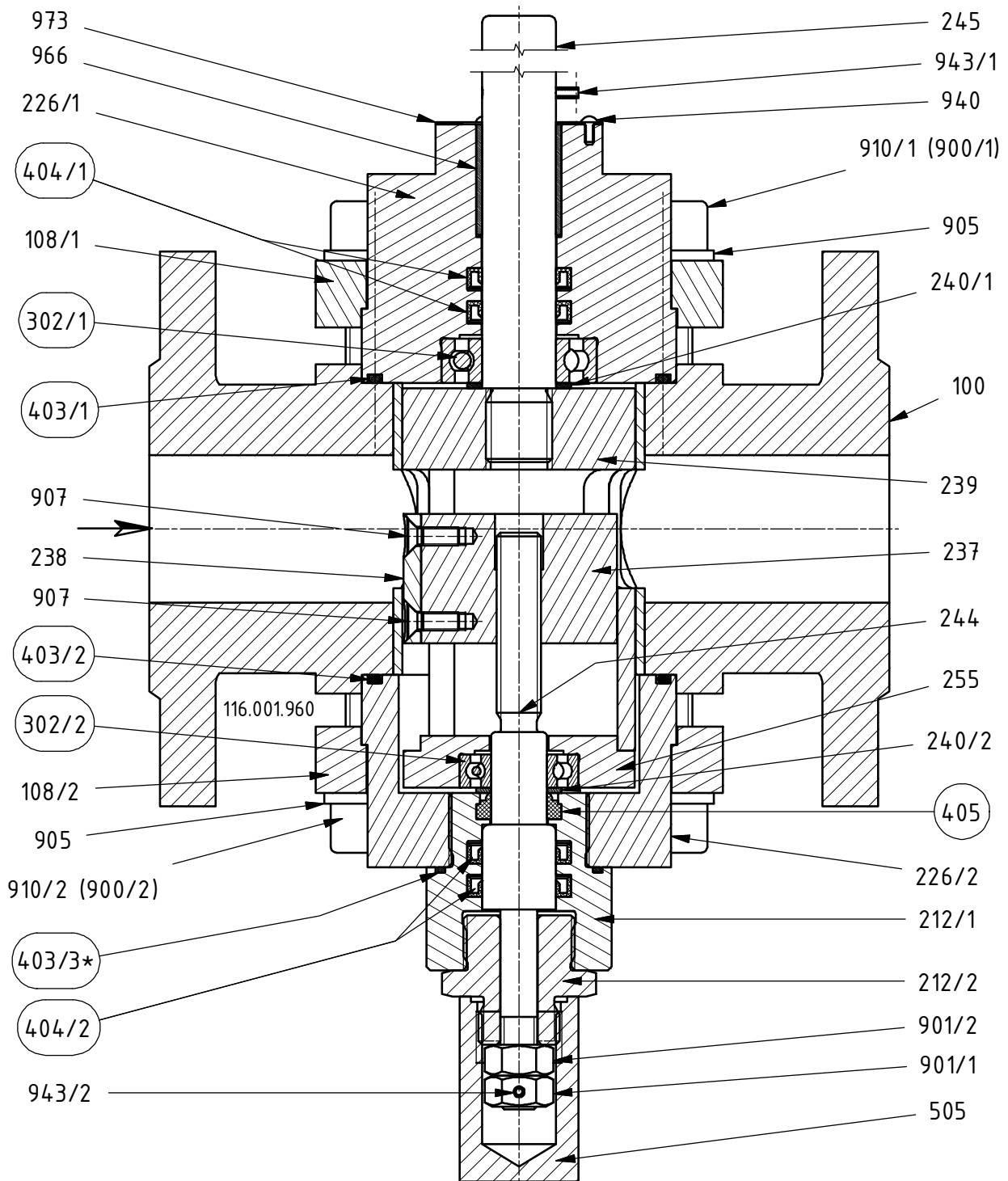

 = Spare part kit

403/3* not applicable for DN 15 – DN 25

Fig.2 Sectional drawing DN 125 – DN150

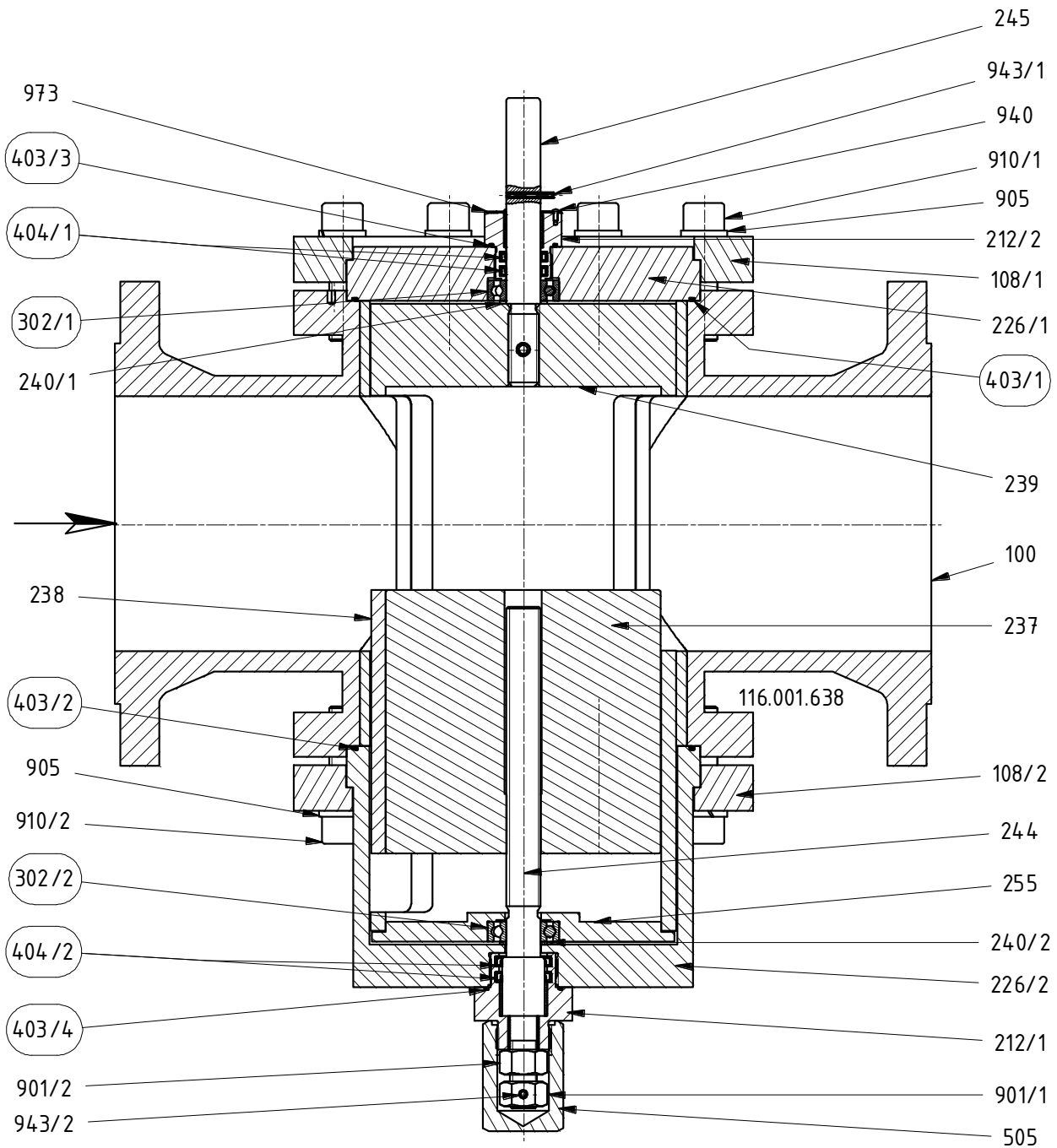

○ = Spare part kit

Fig.3 Sectional drawing DN 200

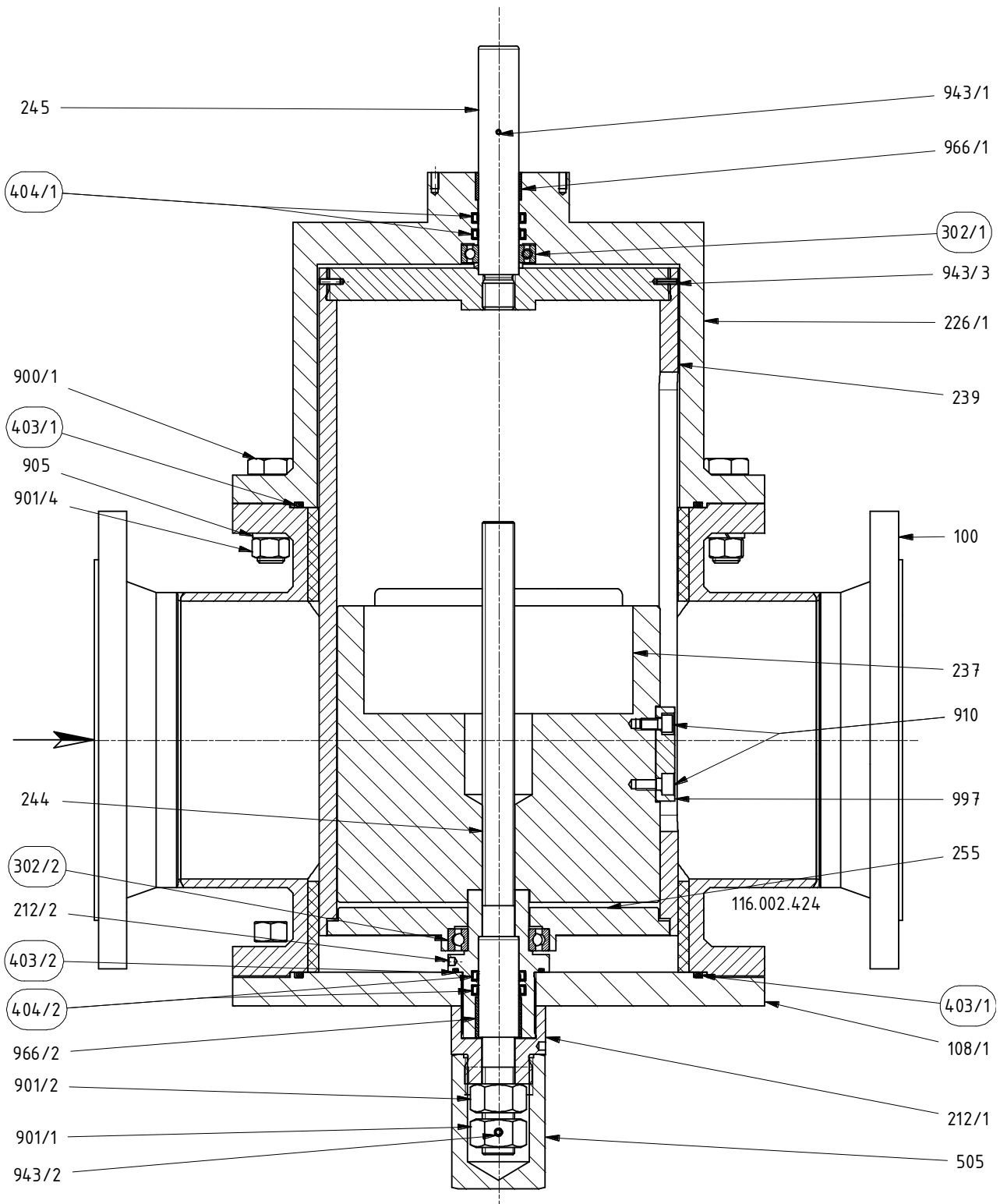

 = Spare part kit

11.2 View drawing

11.2.1 View drawing ...MRS Ro We... DN 15 – DN 50

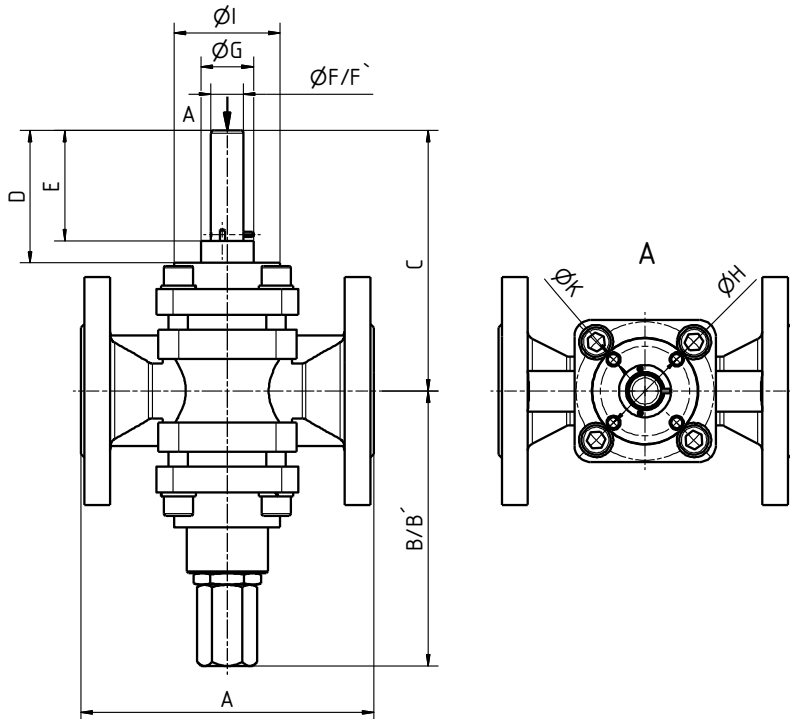

11.2.2 View drawing ...MRS Ro We... DN 65 – DN 100

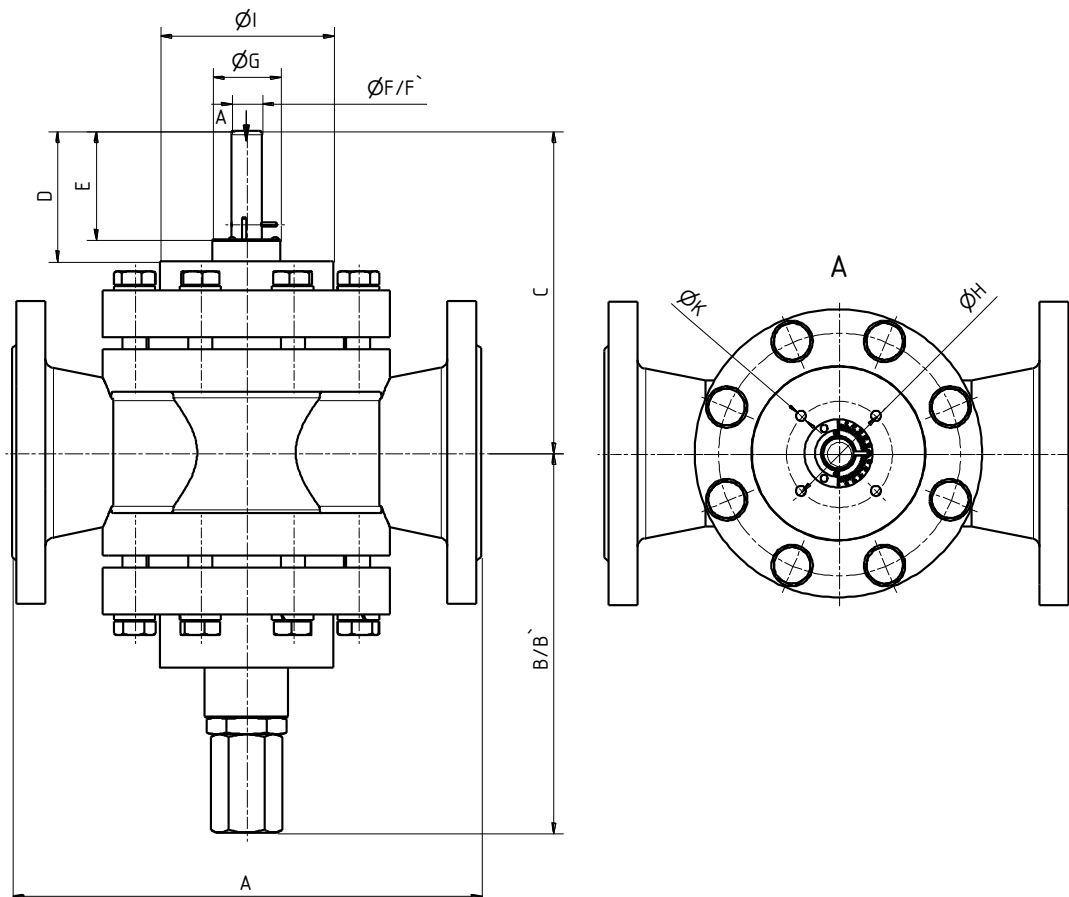

11.2.3 View drawing ...MRS Ro We... DN 125 – DN 150

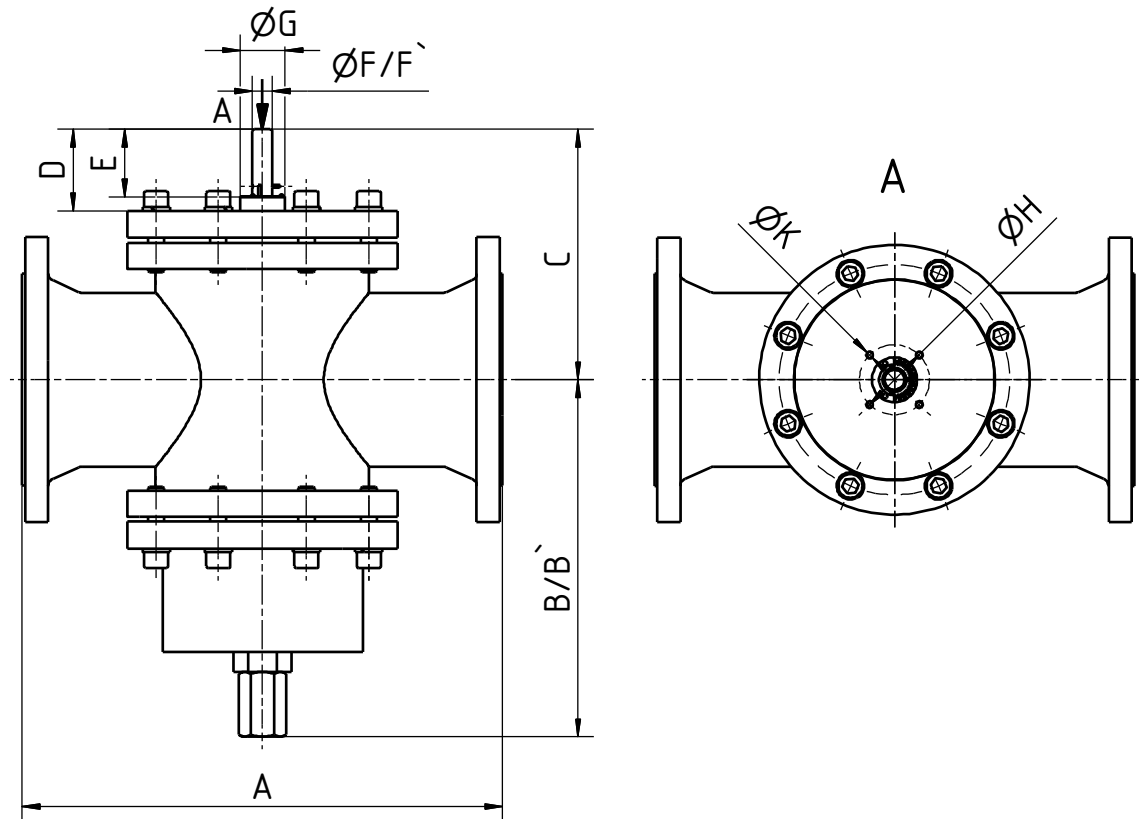

11.2.4 View drawing ...MRS Ro We... DN 200

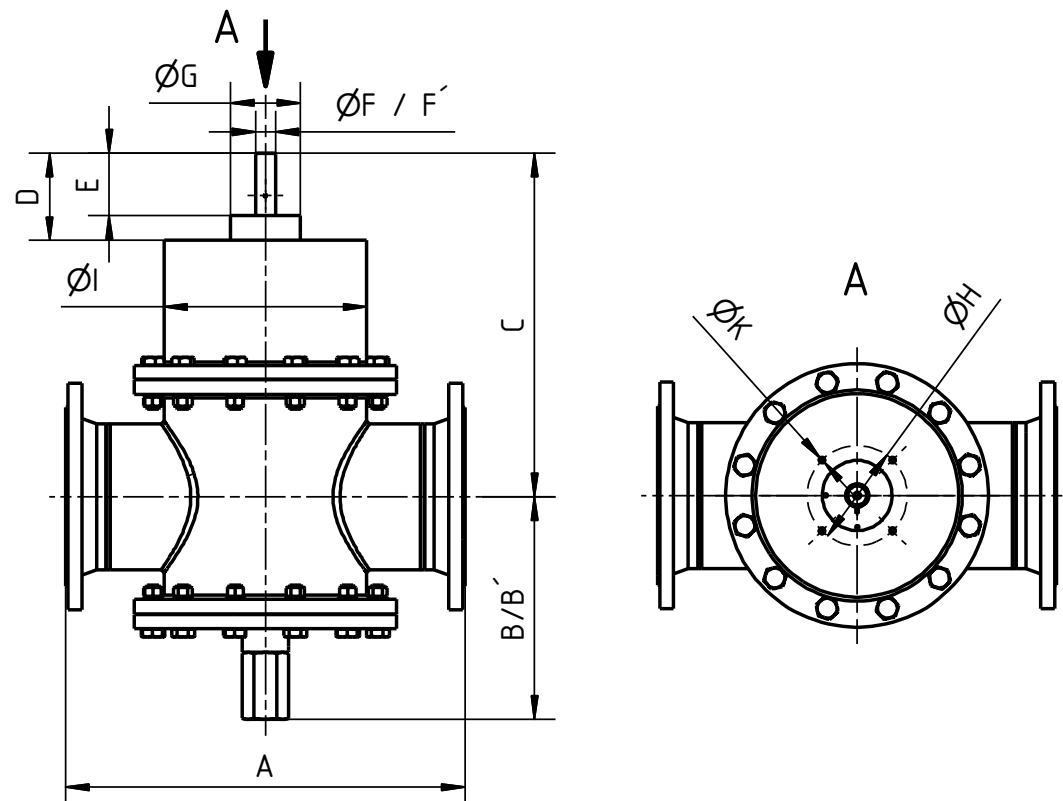

11.2.5 View drawing ...MRS Ro St...

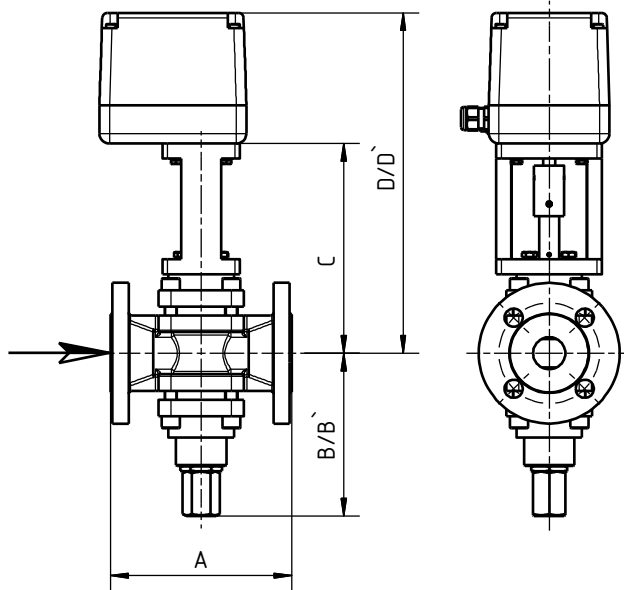

11.2.6 View drawing ...MRS Ro St (series NE)

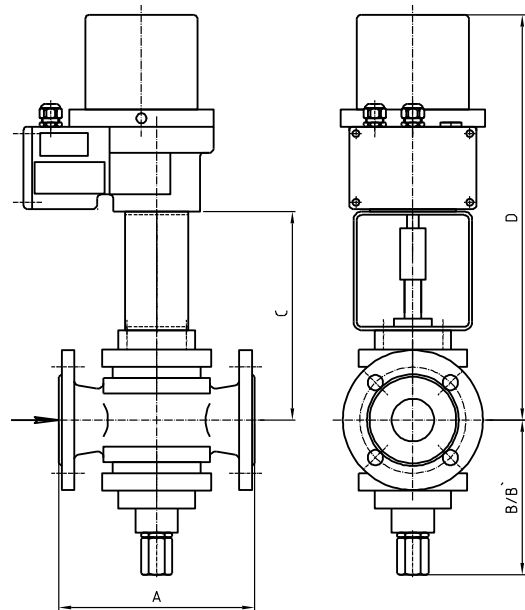

11.2.7 View drawing ...MRS Ro Pn...

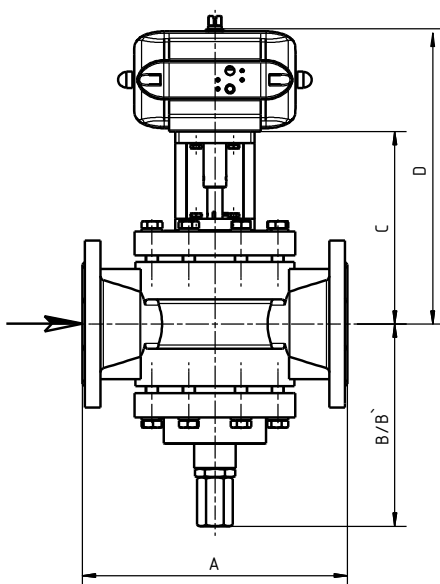

11.2.8 View drawing MRS Ro Pn.. /positioner

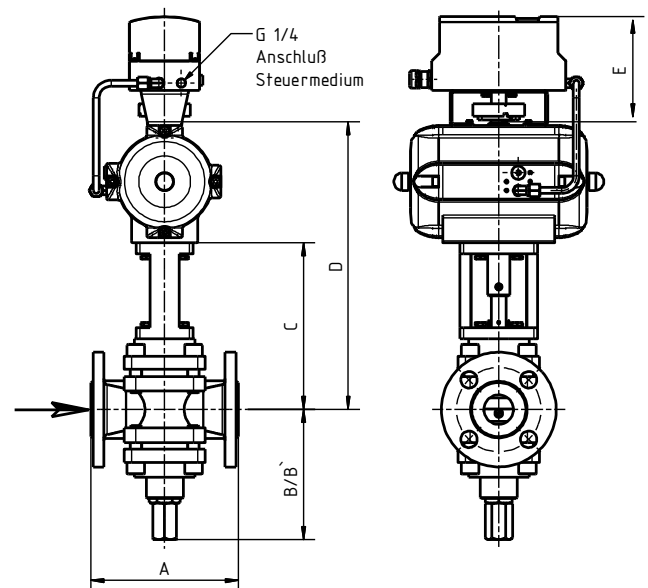

11.3 List of parts

Pos./ Item	St. / Qty.	Benennung	Description
100	1	Ventilgehäuse	valve chamber
108/1	1	Gehäuseflansch	housing flange
108/2	1	Gehäuseflansch	housing flnage
212/1	1	Spindelführung	spindle guide
212/2	1	Spindelführung	spindle guide
212/3	1	Spindelführung	Spindle guide
226/1	1	Dichtstück	sealing piece
226/2	1	Dichtstück	sealing piece

Pos./ Item	St. / Qty.	Benennung	Description
237	1	Mengeneinstellzylinder	volume adjusting cylinder
238	1	Kulisse	guard
239	1	Regelzylinder	control cylinder
240/1	1	Scheibe (MRS)	disk (MRS)
240/2	1	Scheibe (MRS)	disk (MRS)
244	1	Mengeneinstellspindel	volume adjusting spindle
245	1	Mengenregelspindel	volume control spindle
255	1	Führungsteil	guide piece
302/1	1	Rillenkugellager	deep groove ball bearing
302/2	1	Rillenkugellager	deep groove ball bearing
403/1	1/2	O-Ring	o-ring
403/2	1	O-Ring	o-ring
403/3	1	O-Ring	o-ring
403/4	1	O-Ring	o-ring
404/1	2	Lippenring	lip-ring
404/2	2	Lippenring	lip-ring
405	1	Abstreifring	Scraper ring
505	1	Schutzkappe	protective cap
900/1	8/12	Sechskantschraube	hex. head screw
900/2	8/12	Sechskantschraube	hex. head screw
901/1	1	Sechskantmutter	hex. nut
901/2	1	Sechskantmutter	hex. nut
901/3	12	Sechskantmutter	hex. nut
901/4	12	Sechskantmutter	hex. nut
905	4/8/12/24	Federring	lock washer
907	2	Senkschraube	countersunk bolt
910	2	Zylinderschraube	cylinder head screw
910/1	4/8	Zylinderschraube	cylinder head screw
910/2	4/8	Zylinderschraube	cylinder head screw
940	3	Halbrundniete	semi-round rivetting
941	1	Gewindestift	setscrew
943/1	1	Spannstift	spring dowel sleeve
943/2	1	Spannstift	spring dowel sleeve
943/3	4	Spannstift	spring dowel sleeve
966/1	1	DU-Buchse	DU liner
966/2	1	DU-Buchse	DU liner
973	1	Skala	scale
997	1	Passfeder	adjusting spring

11.4 Dimension MRS Ro We....

Flange DN	Dimension	15 (5N)	20 (7N)	25 (10N)	32 (12N)	40 (15N)	50 (20N)	65 (25N)	80 (30N)	100	125	150	200	
Installation length	A	130	150	160	180	200	230	290	310	350	400	480	608	
	B	156	156	160	170	177	184	238	251	267	319	358	335	
10-MRS...(N)-4	B`	206	208	210	220	227	234	288	301	317	369	433	435	
	C	153	158	161	160	182	191	206	213	207	240	251	508	
	D	84	86	82	82	86	85	88	86	84	77	82	139	
	E	71	73	68	68	73	71	74	72	69	72	68	102	
	ØF	15	15	20	20	20	20	20	20	20	20	20	30	
	ØF`	15	15	15	15	15	15	15	15	15	15	15	-	
	G	24	24	32	32	45	45	45	45	45	45	45	60	
	H	38	38	46	55	70	70	70	70	70	70	70	150	
	I	48	48	58	65	82	90	95	115	135	195	200	305	
	K	M6	M6	M6	M8	M8	M8	M8	M8	M8	M8	M8	M8	M10

A = Dimension at DIN (resp. flanges ANSI and dimension DIN or flanges and dimension at DIN)

B` = Dimension for removal of the protective cap

ØF` = Dimension for customer-specific volume control spindle

Dimension ..-MRS Ro St... (electrical actuator)

Flange DN	Dimension	15 (5N)	20 (7N)	25 (10N)	32 (12N)	40 (15N)	50 (20N)	65 (25N)	80 (30N)	100	125	150	200
Installation length	A	130	150	160	180	200	230	290	310	350	400	480	608
	MRS...(N)-4												
	B	156	156	160	170	177	184	238	251	267	319	358	335
	B`	206	208	210	220	227	234	288	301	317	369	433	435
with actuator of series NL (NL3020, NL3040, NL6020, NL6040)													
	C	199	202	209	209	226	236	248	257	253	293	299	499
	D	329	332	339	339	356	366	378	387	383	423	429	629
with positioner of series PMR 2-LC													
	D`	385	388	395	395	412	422	434	443	439	479	485	685
with actuator of series NK (NK6010, NK6015) with optional integrated positioner PMR-NK													
	C	204	207	214	214	231	241	253	262	258	298	304	504
	D/D`	328	331	338	338	355	365	377	386	382	422	428	628
with actuator of series N (N1, N2, N2A, N3, N4A, N5A, N5)													
	C	199	202	209	209	226	236	248	257	253	293	299	499
	D	329	332	339	339	356	366	378	387	383	423	429	629
with actuator of series N (N1, N2, N2A, N3, N4A, N5A, N5)													
	D`	385	388	395	395	412	422	434	443	439	479	485	685

B` = Dimension for removal of the protective cap

D` = Dimension with integrated positioner

Dimension ..-MRS Ro Pn... (pneumatic actuator)

Flange DN	Dimension	15 (5N)	20 (7N)	25 (10N)	32 (12N)	40 (15N)	50 (20N)	65 (25N)	80 (30N)	100	125	150	200
Installation length	A	130	150	160	180	200	230	290	310	350	400	480	608
	MRS...(N)-4												
	B	156	156	160	170	177	184	238	251	267	319	358	335
	B`	206	208	210	220	227	234	288	301	317	369	433	435
	C	199	202	209	209	226	236	248	257	253	293	299	499
with rotary actuator PGF 07													
	D	266	269	276	276	293	303	315	324	320	360	366	566
with rotary actuator PGF 10													
	D	294	297	304	304	324	331	343	352	348	388	394	594
with rotary actuator PGF 15													
	D	310	313	320	320	337	347	359	368	364	404	410	610
with rotary actuator PGF 20													
	D	332	335	342	342	359	369	381	390	386	426	432	632
with rotary actuator PGF 25													
	D	358	361	368	368	385	395	407	416	412	452	458	658
with rotary actuator PGF 30													
	D	373	376	383	383	400	410	422	431	427	467	473	673
with rotary actuator PGF 33													
	D	401	404	411	411	428	438	450	459	455	495	501	701
with rotary actuator PGF 35													
	D	416	419	426	426	443	453	465	474	470	510	516	716
with rotary actuator Sipart PS2 (6DR5010 / 6DR5020)													
	E	145	145	145	145	145	145	145	145	145	145	145	145

12.0 Declaration of Conformity

UNI-Geräte E. Mangelmann
Elektrotechnische Fabrik GmbH
Holtumsweg 13
D – 47652 Weeze



EU

Konformitätserklärung Declaration of Conformity

Produkt / Product	Stellgerät ohne Nullabschluss / Actuator without zero shut off		
Handelsbezeichnung / Trade Mark	Mengenregelschieber / Flow control slide valve		
Baureihe / Series	...MRS...		
Nennweiten / Size	DN 15^{a)} / 20^{a)} / 25^{a)} / 32^{a);b)} / 40^{a);b)} / 50^{a);b)} / 65^{a);b)} / 80^{a);b)} / 100^{a);b)} / 125^{a);b)} / 150^{a);b)} / 200^{a);b)}		
Druckstufe / Pressure Stage	PN 10^{a);b)} / 16^{a);b)} / 25^{a);b)} / 40^{a);b)}		
Medium / medium	Brennbare Gase der 1., 2. und 3. Gasfamilie / Flammable gases of the 1., 2. and 3. gasfamily		
EU - Richtlinien / EU - Directives	EU/2016/426^{a)} Gasgeräteverordnung / Gas Appliance Regulation 2014/68/EU^{b)} Druckgeräterichtlinie / Pressure Equipment Directive		
Konformitätsbewertungsverfahren / Conformity Assessment Procedure	Modul B + D - EU/2016/426^{a)}; Modul H - 2014/68/EU^{b)}		
Angewandte technische Spezifikation / Applied Technical Specification	a) DIN EN 16678:2016-02; DIN EN 13611:2016-09; b) DIN EN 16668:2018-05; DIN EN 12266:2012-04		
Baumusterprüfung / Type Examination	CE-0085AQ0616^{a)}	EU/2016/426	Modul B
	DVGW CERT GmbH Josef-Winter-Str. 1-3 D-53123 Bonn Zertifizierungsstelle / Notified Body 0085		
Überwachungsverfahren / Surveillance Procedure	SE-0085BL7038^{a)}	EU/2016/426	Modul D
	DVGW CERT GmbH Josef-Winter-Str. 1-3 D-53123 Bonn Zertifizierungsstelle / Notified Body 0085		
	CE-0062-PED-H-UGM 001-23-DEU^{b)}	2014/68/EU	Modul H
	Bureau Veritas Services SAS 8 Cours du Triangle 92800 PUTEAUX – LA DEFENSE Zertifizierungsstelle / Notified Body 0062		
Kennzeichnung / Marking	CE - 0085^{a)} 0062^{b)} oder/lor CE - 0085^{a)}		

Das Unternehmen UNI Geräte E. Mangelmann Elektrotechnische Fabrik GmbH erklärt in alleiniger Verantwortung, dass die o.a. Baureihe die grundsätzlichen Anforderungen der aufgeführten Richtlinien und Normen erfüllt.

UNI Geräte E. Mangelmann Elektrotechnische Fabrik GmbH confirms under the sole responsibility of the manufacturer, that the basic requirements of the above specified directives and standards are fulfilled.

Weeze, 24.01.2023

Ort und Datum / place and date

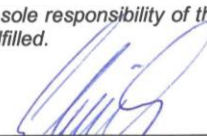
Geschäftsführer / Managing Director
Norbert Schneider

a); b) Anwendung in Abhängigkeit von Nennweite und / oder Druckstufe: / Application depending on size and / or pressure stage:
DN ≤ 25 und / oder PS ≤ 0,5bar siehe Diagramm 6, oder Kat.1 + erfasst von EU/2016/426, fallen nicht in den Anwendungsbereich der 2014/68/EU
DN ≤ 25 and / or PS ≤ 0,5bar see diagram 6, or Kat.1 + under the scope of EU/2016/426, are not covered by the scope of the EU-Directive 2014/68/EU 250.100.007-04

UNI-Geräte E. Mangelmann
Elektrotechnische Fabrik GmbH
Holtumsweg 13
D – 47652 Weeze

UK Declaration of Conformity UK Konformitätserklärung

We / Wir:

UNI-Geräte E. Mangelmann
Elektronische Fabrik GMBH
Holtumsweg 13
D – 47652 Weeze

Declare that / Erklären hiermit:

Product / Produkt

Functional Control – without zero obturation
Stellgerät – ohne Nullabschluss

Trade Mark / Handelsbezeichnung

Flow control slide valve / Mengenregelschieber

Series / Baureihe

...MRS...

Size / Nennweiten

DN 15 / 20 / 25 / 32 / 40 / 50 / 65 / 80 / 100 / 125 / 150 / 200

Pressure Stage / Druckstufe

PN 16 / 25 / 40

Fluid Group / Fluidgruppe

Gas type of the 1st, 2nd and 3rd family gases
Gasart der 1., 2. und 3. Gasfamilie

Satisfies the essential requirements of the Regulation 2016/426 on gas appliances as brought into UK law and amended and is manufactured in accordance with the UK designated standards:

Erfüllt die grundlegenden Anforderungen der Verordnung 2016/426 für Gasgeräte in der im Vereinigten Königreich geltenden und geänderten Fassung und wird in Übereinstimmung mit den im VK festgelegten Normen hergestellt:

Standards Numbers / Normen Nummern: BS EN 161:2011+A3:2013, BS EN 16678:2015

BSI has performed the following conformity assessment procedures specified in the Regulation 2016/426 on gas appliances as brought into UK law and amended:

Das BSI hat die folgenden Konformitätsbewertungsverfahren durchgeführt, die in der Verordnung 2016/426 für Gasgeräte, wie sie in britisches Recht umgesetzt und geändert wurde, festgelegt sind:

Annex III Module B (Type Examination) and issued the Certificates below:

UKCA Module B certificate: (Certificate No.) UKCA 772967

Anhang III Modul B (Baumusterprüfung) geprüft und die nachstehenden Bescheinigungen ausgestellt:

UKCA-Modul-B-Zertifikat: (Zertifikats-Nr.) UKCA 772967

Annex III Module D (Conformity to Type based on Quality Assurance of the Production Process) and issued the Certificates below:

UKCA Module D certificate: (Certificate No.) UKCA 772905

Anhang III Modul D (Konformität mit der Bauart auf der Grundlage der Qualitätssicherung des Produktionsprozesses) und stellte die nachstehenden Zertifikate aus:

UKCA-Modul-D-Zertifikat: (Zertifikats-Nr.) UKCA 772905

Approved Body / Zugelassene Stelle: BSI Assurance UK Limited (Approved Body No. 0086)

Address / Adresse: Kitemark Court, Davy Avenue,
Knowlhill Milton Keynes MK5 8PP UK.

This declaration of conformity is issued under the sole responsibility of the manufacturer.

Diese Konformitätserklärung wird unter der alleinigen Verantwortung des Herstellers ausgestellt.

Name / Name:

Norbert Schneider

Title / Position / Funktion:

Dipl. Ing. / Managing Director / Geschäftsführer

Place & date of issue /

D – 47652 Weeze, 22.02.2023

Ort und Datum der Ausstellung:

Signature / Unterschrift:



250.100.582-00