



# Solenoid actuator

Series MG...x, MG...-A...x

With  protection for use for correct purpose in  
Ex zone 1 and 21 according to 2014/34/EU (ATEX) 



## Operating instructions

(translation)

### Basics

Valve / solenoid actuator combinations are delivered fully assembled and tested as standard. When solenoid actuators are replaced or changed, it must be ensured that combination with a UNI fitting is approved and that the magnet is properly attached to the fitting (e.g. with the permissible tightening torque). The device-specific serial number and the year of manufacture can be found on the nameplate for clear identification.

Solenoid actuators are electrotechnical components which cannot be operated without an associated fitting, and may not be operated on their own! Always use solenoid actuators with IP65 with a rain protection cover for outdoor installations. Solenoid actuators which are obviously damaged must not be installed and must be replaced. If the solenoid actuators are exposed to special types of external stress, additional protective measures are required and must be provided by the operator. Any modifications to the device which are undefined or have not been agreed can have a negative influence on the explosion protection, and in the worst case it may even be cancelled out altogether. UNI-Geräte does not accept liability for damage (to the device / beyond) caused by modification(s) to the device. The same applies to warranty claims.

### Explosion protection

The solenoid actuators and the integrated solenoid valve controls comply with the explosion protection types "db" and "eb" in device category II2G, as well as "tb", device category II2D. They can be used in areas in which explosive mixtures of air and combustible gas, vapour, aerosol or dust may occur, i.e. in Ex zone 1 / 21. The electrical and thermal parameters of the separate variants can be obtained from the respective type plates. The explosion protection applies to operation of the device. The relevant explosion protection regulations, particularly EN 60079-14 (VDE 0165-1), must be observed during installation, maintenance or repair. The electrical installation must be carried out by a qualified electrician or under the supervision thereof, taking the relevant national regulations into consideration. Prior to installation, the device specifications must be compared with the intended operating conditions in order to ensure that proper operation takes place.

### Description of the device

The solenoid actuator (pot magnet) is used as a drive unit for valves. Constructionally the actuator consists of a magnet housing (flameproof enclosure, magnetic disk and chamber cover with terminal compartment), a coil and electronics. Depending on the version, the solenoid actuator can be operated with direct or alternating voltage. A rectifier is built into the AC voltage version. The various types of coils therefore always have direct current flowing through them when they are live. The MG...x solenoid actuators have a conventional coil with one winding and the resulting average permanent attraction forces with average power consumption during continuous operation. The type MG...-A...x solenoid actuators, on the other hand, have two windings on their coil body, a pull-in winding and a hold-in winding. The installed TS200 / TS900 / TS1500 valve controller switches from the pull-in winding to the hold-in winding or from higher to lower power after a defined time. In this way, very high pull-in forces with simultaneous continuous (hold-in) operation can be achieved for short periods with low power consumption.

### Specific conditions of use



Repairs on flameproof joints may only be performed in accordance with design specifications provided by UNI-Geräte. Repairs based on the values in table 3 of EN 60079-1:2014 are not permitted.

---

UNI-Geräte E. Mangelmann Elektrotechnische Fabrik GmbH  
Holtumsweg 13, 47652 Weeze, Germany, Tel. +49 2837/9134-0, Fax +49 2837/1444  
www.uni-geraete.de info@uni-geraete.de

# Solenoid actuator

Series MG...x, MG...-A...x

With  protection for use for correct purpose in  
Ex zone 1 and 21 according to 2014/34/EU (ATEX) 



## Notes on installation and safe operation

- Only heat-resistant connecting cables with an upper operating temperature of at least 100 ° C may then be used to connect the solenoid actuator.
- The emergence of explosive atmospheres is to be avoided in the region of the magnetic core and guide tube.
- With respect to paintwork, it must be ensured that the total thickness of the coating is not to exceed the tolerance of 0.2 mm (200 µm) from EN IEC 60079-0:2018 Table 9.
- The solenoid actuator is not to be subjected to any charge-generating processes (presence of accelerated particles on the surface, e.g. electrons from high-voltage electrodes, flowing powder particles or liquids).

## Electrical connection



- The diameter range / clamping range of the cable gland must be noted and adhered to.
- When flexible connecting cables are being used, insulated wire end sleeves with plastic collars in accordance with DIN 46228-4 must be used.
- The supply voltage at the solenoid actuator must be within the range of –15% to +10% of the nominal voltage. The connection is performed to the wiring diagram in these operating instructions.
- The magnet housing cover must be reassembled with care in order to guarantee the IP protection class. Versions which are delivered with a connecting cable from the factory are ready for use, i.e. the terminal compartment does not need to be opened.
- The solenoid actuators must be protected against the dangerous effects of short circuits, earth faults and overloading. Upstream protective devices must be of a type which prevents automatic restarting under fault conditions. Their rated voltage must be equal to or greater than the nominal voltage of the solenoid actuator. Their breaking capacity must be equal to or greater than the maximum short-circuit current which can be assumed at the installation site (usually 1500 A).
- An upstream fuse for protecting the device must be rated with a maximum of 3 times the nominal current of the solenoid actuator (in accordance with IEC 60127-1). If the rated current is very small, the fuse with the smallest current value in accordance with the specified IEC standard must be selected. With solenoid actuators with pull-in/hold-in control (MG...-A...x), the higher value (pull-in current) must be taken into consideration.
- An upstream motor protection switch with short-circuit tripping and a thermal quick release must be set to the nominal current of the solenoid actuator. With solenoid actuators with pull-in/hold-in control (MG...-A...x), the higher value (pull-in current) must be taken into consideration. Based on its characteristic curve, the motor protection switch must be set so that it trips after 20 s with a pull-in current.
- The length and cable cross-section of the connecting cable should be dimensioned so that a maximum voltage drop of 4% (in accordance with VDE 0100-520) is not exceeded. The "recommended maximum cable length" tables for the respective actuator types can be used for the calculation.
- If a silicone (or silicone-containing) connecting cable or a cable that is not scratch-resistant is being used, it must be protected against mechanical damage (e.g. by an interrupted tube system with edge protection).
- A maximum permissible ripple of 20% applies to all solenoid actuators with the direct current design.

---

UNI-Geräte E. Mangelmann Elektrotechnische Fabrik GmbH  
Holtumsweg 13, 47652 Weeze, Germany, Tel. +49 2837/9134-0, Fax +49 2837/1444  
www.uni-geraete.de info@uni-geraete.de

# Solenoid actuator

Series MG...x, MG...-A...x

With  protection for use for correct purpose in  
Ex zone 1 and 21 according to 2014/34/EU (ATEX) 



## CE markings

The Council of the European Union has issued common directives for the free movement of goods within the Union, which specify minimum requirements for health and safety protection. The CE mark confirms that products are compliant with the EU directives, i.e. compliant with the relevant standards, particularly the harmonized ones.

### Note concerning directive 2014/34/EU (Explosion directive / ATEX directive):

The solenoid actuators fulfil the relevant requirements of Directive 2014/34/EU. Therefore, they bear the CE mark according to Annex II of the directive. The declaration of conformity is enclosed.

### Note concerning directive 2014/30/EU (EMC directive):

The solenoid actuators fulfil the requirements of the product family standards to be used in the industrial sector and also in the residential, business and commercial sectors as well as in small businesses. When AC and DC versions are being used, the user must provide a suitable line filter (e.g. X-capacitor 47 nF) at the power supply input in order to attenuate the physically-related cable-bound switch-off interference of the solenoid. Solenoid actuators as drive elements for valves do not represent independently operating devices in the sense of the EMC directive, and are only subjected to further processing or installed into a machine by specialist companies. Starting up is not allowed until it has been established that the entire machine or system complies with the provisions of the EMC directive.

## Operation

100% duty cycles are also permitted at the most unfavourable ambient temperatures.



### **WARNING!**



#### **Risk of injury from hot surfaces!**

- Do not touch the solenoid actuator when in operation without suitable personal protection equipment.

When in operation, ensure that the maximum surface temperature of 95 °C is not exceeded. This is guaranteed if neither the maximum permissible ambient and medium temperature nor the maximum permissible supply voltage level are exceeded. The solenoid actuator must be protected from inadmissible heating if necessary. All solenoid actuators are wired with a protective measure to reduce the induction voltage. To avoid potentially damaging residual induction voltage, the user must take suitable measures that go beyond the built-in protective measures if necessary.

# Solenoid actuator

Series MG...x, MG...-A...x

With  protection for use for correct purpose in  
Ex zone 1 and 21 according to 2014/34/EU (ATEX) 



## Disassembly of the solenoid actuator

The solenoid actuator must be taken out of operation before dismantling.



### WARNING!

#### Risk of injury from hot surfaces!

- Only touch the solenoid actuator with suitable personal protective equipment.
- Prior to dismantling, allow the solenoid actuator to cool off.



### WARNING!

#### Danger of electric shock!

- De-energize the solenoid actuator prior to opening the housing.
- Observe the electrical safety rules.
- The device may only be connected by a qualified electrician.



### WARNING!

#### Danger of explosion!

- Components inside the solenoid actuator may exceed the maximum permissible surface temperature of 95 °C.
- Prior to opening the housing, a cooling off time of 120 minutes is to be observed.

Undo cheese head screws (910/3) and remove with the spring rings (905/3). Remove the magnet housing cover (105) from the Ex chamber cover (127). Disconnect the connecting cable from the terminals of the cable bushing (733). Undo cheese head screws (910/2) and remove with the spring rings (905/2).



### CAUTION!

The Ex chamber cover (127) is not to be separated from the magnet housing (103) using sharp objects (e.g., a screwdriver)!

Lift the Ex chamber cover (127) off the magnet housing (103). For solenoid actuators MG..x, disconnect the conductors on the terminal or the rectifier, or for solenoid actuators MG...-A...x on the terminal of the transistor controller (TC....), then remove the Ex chamber cover (127) and place it with the top side onto a clean surface.

Undo cheese head screw (910/1) and remove with the spring ring (905/1). By screwing two cheese head screws (M8 x 40mm) into the magnetic disk (500), it can be removed from the top part of the housing (106).





### NOTE!

The coiled spring pins (943/1) and (943/2) are in the magnetic disk (500) and must be hammered out during dismantling.

Remove the magnet housing (103) from the top part of the valve housing (106) and take out the solenoid coil (702) where needed.

# Solenoid actuator

Series MG...x, MG...-A...x

With  protection for use for correct purpose in  
Ex zone 1 and 21 according to 2014/34/EU (ATEX) 



## Assembly of the solenoid actuator

Assembly takes place in reverse order as the dismantling.



### CAUTION!

The metallic contact and gap surfaces between the magnet housing (103) and the top part of the valve housing (106), as well as between the magnet housing (103) and the Ex chamber cover (127) form flameproof gaps. They must be free of defects such as scratches, for example. A repair or refurbishment of these surfaces is not allowed! The surfaces are to be lubricated with Klüberplex BE 31-222 lubricant.

When tightening the cheese head screw (910/1), the gap width between the magnetic disk (500) and the top part of the housing (106) must be 0.05 - 0.1mm. The dimension is to be determined using a calliper gauge.



### NOTE!

The solenoid actuator and the top part of the valve housing (106) have been custom fitted in the factory. The installation of a substitute actuator may only be put into operation according to the express specification of UNI-Geräte or by UNI-Geräte itself!



### NOTE!



When installing the magnet disc (500), ensure that the coiled spring pins (943/1) and (943/2) for locking the top part of the valve housing (106) and the magnet housing (103) are tapped back into the magnetic disk (500).

## Tightening torques of the cheese head screws (910/X)

| Position | Number | Connection   | Thread | Tightening torque |
|----------|--------|--|--------|-------------------|
| 910/1    | 1      | Magnetic disk (500) /<br>top part of the valve housing (106) | M8     | 30 Nm             |
|          |        |  | M10    | 30 Nm             |
| 910/2    | 4      | Ex chamber cover (127) /<br>magnet housing (193)             | M10    | 50 Nm             |
|          |        |  | M12    | 50 Nm             |
| 910/3    | 3      | Magnet housing cover (105) /<br>Ex chamber cover (127).      | M6     | 4.6 Nm            |

# Solenoid actuator

Series MG...x, MG...-A...x

With  protection for use for correct purpose in  
Ex zone 1 and 21 according to 2014/34/EU (ATEX) 



## Solenoid actuator MG...x, MG...-A...x

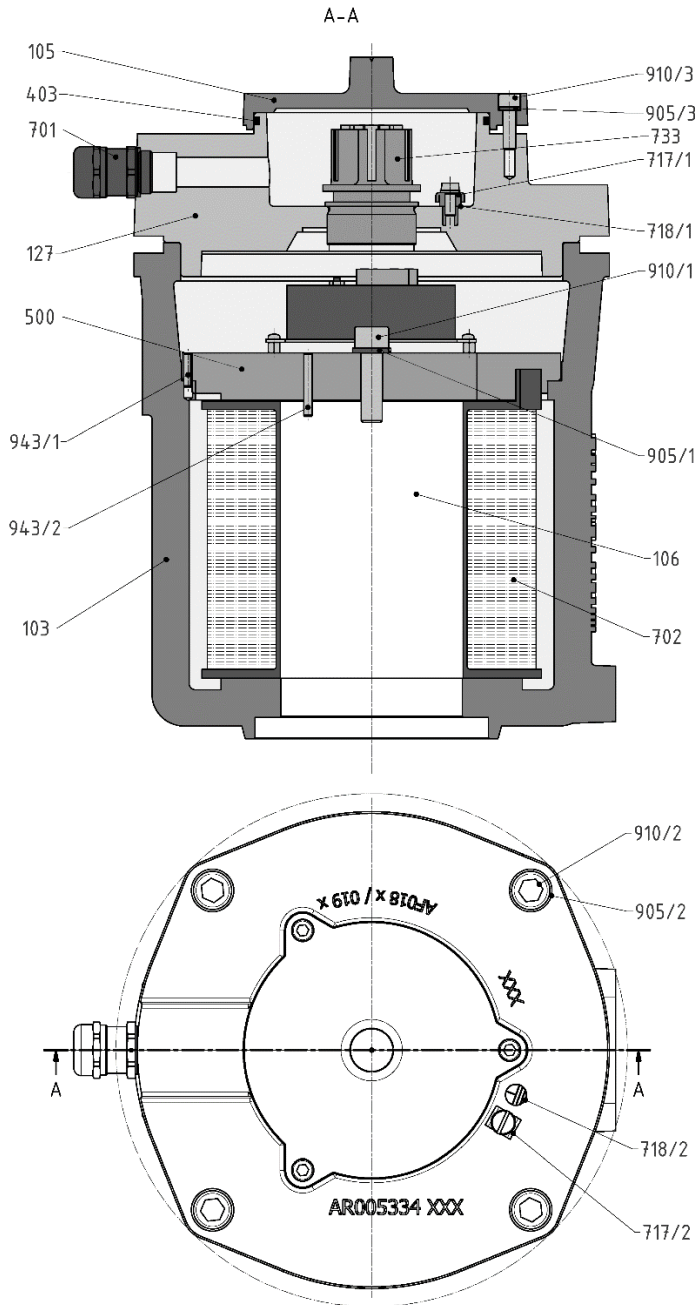



| Item  | Unit | Designation                   |
|-------|------|-------------------------------|
| 103   | 1    | Magnet housing                |
| 105   | 1    | Magnet housing cover          |
| 106   |      | Top part of the valve housing |
| 127   | 1    | Ex chamber cover              |
| 403   | 1    | O-ring                        |
| 500   | 1    | Magnetic disk                 |
| 701   | 1    | Cable gland                   |
| 702   | 1    | Solenoid coil                 |
| 717/1 | 1    | Earthing terminal (inner)     |
| 717/2 | 1    | Earthing terminal (external)  |
| 718/1 | 1    | Earthing symbol (inner)       |
| 718/2 | 1    | Earthing symbol (external)    |
| 733   | 1    | Cable bushing                 |
| 905/1 | 1    | Spring ring                   |
| 905/2 | 4    | Spring ring                   |
| 905/3 | 3    | Spring ring                   |
| 910/1 | 1    | Cheese head screw             |
| 910/2 | 4    | Cheese head screw             |
| 910/3 | 3    | Cheese head screw             |
| 943/1 | 1    | Coiled pin                    |
| 943/2 | 1    | Coiled pin                    |

UNI-Geräte E. Mangelmann Elektrotechnische Fabrik GmbH  
Holtumsweg 13, 47652 Weeze, Germany, Tel. +49 2837/9134-0, Fax +49 2837/1444  
www.uni-geraete.de info@uni-geraete.de



# Solenoid actuator

Series MG...x, MG...-A...x

With  protection for use for correct purpose in  
Ex zone 1 and 21 according to 2014/34/EU (ATEX) 



## Technical data



|   |  |
|---|--|
| Ex marking:   |  II 2 G Ex db eb IIC T5 Gb  |
|   |  II 2 D Ex tb IIIC T95°C Db |
| Protection type:                                    | IP65   |
| Max. housing temperature:                           | 95 °C  |
| Ambient temperature:                                | -20 to +60 °C  |
| Media temperature:                                  |  |
| Top part of the valve housing with media contact    | -20 to +60 °C  |
| Top part of the valve housing without media contact | no influence   |
| Duty cycle:   | 100%   |
| Mains frequency for AC version:                     | 40 to 60 Hz  |

---

UNI-Geräte E. Mangelmann Elektrotechnische Fabrik GmbH  
Holtumsweg 13, 47652 Weeze, Germany, Tel. +49 2837/9134-0, Fax +49 2837/1444  
[www.uni-geraete.de](http://www.uni-geraete.de) [info@uni-geraete.de](mailto:info@uni-geraete.de)

# Solenoid actuator

Series MG...x, MG...-A...x

With  protection for use for correct purpose in  
Ex zone 1 and 21 according to 2014/34/EU (ATEX) 



## Solenoid actuator MG...x

| Type<br>MG | P*<br>W | Nominal current A* |            |             |             |             |             |            |             |             |             |             |
|------------|---------|--------------------|------------|-------------|-------------|-------------|-------------|------------|-------------|-------------|-------------|-------------|
|            |         | 24<br>V DC         | 48<br>V DC | 110<br>V DC | 120<br>V DC | 125<br>V DC | 220<br>V DC | 24<br>V AC | 110<br>V AC | 120<br>V AC | 210<br>V AC | 230<br>V AC |
| 008x       | 30      | 1.3                | 0.6        | 0.3         | 0.3         | 0.2         | 0.1         | 1.3        | 0.3         | 0.3         | 0.2         | 0.1         |
| 010x       | 40      | 1.7                | 0.8        | 0.4         | 0.3         | 0.3         | 0.2         | 1.7        | 0.4         | 0.3         | 0.2         | 0.2         |
| 012x       | 50      | 2.1                | 1.0        | 0.5         | 0.4         | 0.4         | 0.2         | 2.1        | 0.5         | 0.4         | 0.2         | 0.2         |
| 014x       | 70      | 2.9                | 1.5        | 0.6         | 0.6         | 0.6         | 0.3         | 2.9        | 0.6         | 0.6         | 0.3         | 0.3         |
| 016x       | 90      | 3.8                | 1.9        | 0.8         | 0.8         | 0.7         | 0.4         | 3.8        | 0.8         | 0.8         | 0.4         | 0.4         |
| 018x       | 125     | 5.2                | 2.6        | 1.1         | 1.0         | 1.0         | 0.6         | 5.2        | 1.1         | 1.0         | 0.6         | 0.5         |
| 019x       | 160     | 6.7                | 3.3        | 1.5         | 1.3         | 1.3         | 0.7         | 6.7        | 1.5         | 1.3         | 0.8         | 0.7         |

\* Nominal power

\*\* Nominal current at nominal voltage and ambient temperature 20°C, 100% duty cycle, stationary heated (at ambient temperature of 20°C at inrush current → nominal current x 1.25)

**Switching frequency:**

1000 switching operations / hour

### Recommended maximum cable length

Cable length for a maximum voltage drop of 4% in accordance with VDE 0100-520

(See sample calculations on page 12)

| Type<br>MG | P<br>W | Length factor* m/mm <sup>2</sup> |            |             |             |             |             |            |             |             |             |             |
|------------|--------|----------------------------------|------------|-------------|-------------|-------------|-------------|------------|-------------|-------------|-------------|-------------|
|            |        | 24<br>V DC                       | 48<br>V DC | 110<br>V DC | 120<br>V DC | 125<br>V DC | 220<br>V DC | 24<br>V AC | 110<br>V AC | 120<br>V AC | 210<br>V AC | 230<br>V AC |
| 008x       | 30     | 17                               | 75         | 343         | 374         | 585         | 2058        | 17         | 343         | 374         | 982         | 2152        |
| 010x       | 40     | 13                               | 56         | 257         | 374         | 390         | 1029        | 13         | 257         | 374         | 982         | 1076        |
| 012x       | 50     | 11                               | 45         | 206         | 281         | 292         | 1029        | 11         | 206         | 281         | 982         | 1076        |
| 014x       | 70     | 8                                | 30         | 172         | 187         | 195         | 686         | 8          | 172         | 187         | 655         | 717         |
| 016x       | 90     | 6                                | 24         | 129         | 140         | 167         | 515         | 6          | 129         | 140         | 491         | 538         |
| 018x       | 125    | 4                                | 17         | 94          | 112         | 117         | 343         | 4          | 94          | 112         | 327         | 430         |
| 019x       | 160    | 3                                | 14         | 69          | 86          | 90          | 294         | 3          | 69          | 86          | 246         | 307         |



\* Cable length = length factor x cable cross-section

UNI-Geräte E. Mangelmann Elektrotechnische Fabrik GmbH  
Holtumsweg 13, 47652 Weeze, Germany, Tel. +49 2837/9134-0, Fax +49 2837/1444  
www.uni-geraete.de info@uni-geraete.de



# Solenoid actuator

Series MG...x, MG...-A...x

With  protection for use for correct purpose in  
Ex zone 1 and 21 according to 2014/34/EU (ATEX) 



## Solenoid actuator MG...A...Xn with internal controller TS900, TS1500

| Type<br><br>MG | P*<br><br>W | Nominal current A** |             |             |             |             |
|----------------|-------------|---------------------|-------------|-------------|-------------|-------------|
|                |             | TS 900              | TS 1500     |             |             |             |
|                |             | 24<br>V DC          | 110<br>V DC | 220<br>V DC | 110<br>V AC | 230<br>V AC |
| 016-Ax         | 720/70      | 30/2.9              | 6.5/0.6     | 3.3/0.3     | 6.5/0.6     | 3.1/0.3     |
| 018-A1x        | 900/70      | 38/2.9              | 8.2/0.6     | 4.1/0.3     | 8.2/0.6     | 3.9/0.3     |
| 018-A2x        | 1200/70     | -                   | 11/0.6      | 5.5/0.3     | 11/0.6      | 5.2/0.3     |
| 019-A1x        | 1200/120    | -                   | 11/1.1      | 5.5/0.6     | 11/1.1      | 5.2/0.5     |
| 019-A2x        | 1500/90     | -                   | 14/0.8      | 6.8/0.4     | 14/0.8      | 6.5/0.4     |
| 019-A5x        | 200/20      | 8.3/0.8             | 1.8/0.2     | 0.9/0.1     | 1.8/0.2     | 0.9/0.1     |

\* Nominal power

\*\* Nominal current at nominal voltage and ambient temperature 20°C, 100% duty cycle, stationary heated (at ambient temperature of 20°C at inrush current → nominal current x 1.25)

**Switching frequency for ambient temp. +20 °C** 20 switching operations / hour

**Switching frequency for ambient temp. +60 °C** 10 switching operations / hour

**Changeover time:** 3 seconds

**Changeover time with opening delay:** 10 seconds

### Recommended maximum cable length

Cable length for a maximum voltage drop of 4% in accordance with VDE 0100-520

(See sample calculations on page 12)



| Type<br><br>MG | P<br><br>W | Length factor* m/mm <sup>2</sup> |             |             |             |             |
|----------------|------------|----------------------------------|-------------|-------------|-------------|-------------|
|                |            | TS 900                           | TS 1500     |             |             |             |
|                |            | 24<br>V DC                       | 110<br>V DC | 220<br>V DC | 110<br>V AC | 230<br>V AC |
| 016-Ax         | 720/70     | 1                                | 16          | 62          | 16          | 69          |
| 018-A1x        | 900/70     | 1                                | 13          | 50          | 13          | 55          |
| 018-A2x        | 1200/70    | -                                | 9           | 37          | 9           | 41          |
| 019-A1x        | 1200/120   | -                                | 9           | 37          | 9           | 41          |
| 019-A2x        | 1500/90    | -                                | 7           | 30          | 7           | 33          |
| 019-A5x        | 200/20     | 3                                | 57          | 229         | 57          | 239         |

\* Cable length = length factor x cable cross-section

UNI-Geräte E. Mangelmann Elektrotechnische Fabrik GmbH  
Holtumsweg 13, 47652 Weeze, Germany, Tel. +49 2837/9134-0, Fax +49 2837/1444  
www.uni-geraete.de info@uni-geraete.de

# Solenoid actuator

Series MG...x, MG...-A...x

With  protection for use for correct purpose in  
Ex zone 1 and 21 according to 2014/34/EU (ATEX) 



## Solenoid actuator MG...A5x with internal controller TS200

| Type<br>MG | P*<br>W | Nominal current A** |             |             |             |             |             |
|------------|---------|---------------------|-------------|-------------|-------------|-------------|-------------|
|            |         | 24<br>V DC          | 110<br>V DC | 220<br>V DC | 110<br>V AC | 230<br>V AC | 240<br>V AC |
| 010-A5x    | 200/20  | 8.3/0.8             | 1.8/0.2     | 0.9/0.1     | 1.8/0.2     | 0.9/0.1     | 0.8/0.1     |
| 012-A5x    |         |                     |             |             |             |             |             |
| 014-A5x    |         |                     |             |             |             |             |             |
| 016-A5x    |         |                     |             |             |             |             |             |
| 018-A5x    |         |                     |             |             |             |             |             |
| 019-A5x    |         |                     |             |             |             |             |             |

\* Nominal power

\*\* Nominal current at nominal voltage and ambient temperature 20°C, 100% duty cycle, stationary heated (at ambient temperature of 20°C at inrush current → nominal current x 1.25)

**Switching frequency:** 600 switching operations / hour

**Changeover time:** 1.5 seconds

### Recommended maximum cable length

Cable length for a maximum voltage drop of 4% in accordance with VDE 0100-520

(See sample calculations on page 12)



| Type<br>MG | P<br>W | Length factor* m/mm <sup>2</sup> |             |             |             |             |             |
|------------|--------|----------------------------------|-------------|-------------|-------------|-------------|-------------|
|            |        | 24<br>V DC                       | 110<br>V DC | 220<br>V DC | 110<br>V AC | 230<br>V AC | 240<br>V AC |
| 010-A5x    | 200/20 | 3                                | 57          | 229         | 57          | 239         | 281         |
| 012-A5x    |        |                                  |             |             |             |             |             |
| 014-A5x    |        |                                  |             |             |             |             |             |
| 016-A5x    |        |                                  |             |             |             |             |             |
| 018-A5x    |        |                                  |             |             |             |             |             |
| 019-A5x    |        |                                  |             |             |             |             |             |

\* Cable length = length factor x cable cross-section

UNI-Geräte E. Mangelmann Elektrotechnische Fabrik GmbH  
Holtumsweg 13, 47652 Weeze, Germany, Tel. +49 2837/9134-0, Fax +49 2837/1444  
www.uni-geraete.de info@uni-geraete.de

# Solenoid actuator

Series MG...x, MG...-A...x

With  protection for use for correct purpose in  
Ex zone 1 and 21 according to 2014/34/EU (ATEX) 



## Wiring diagram

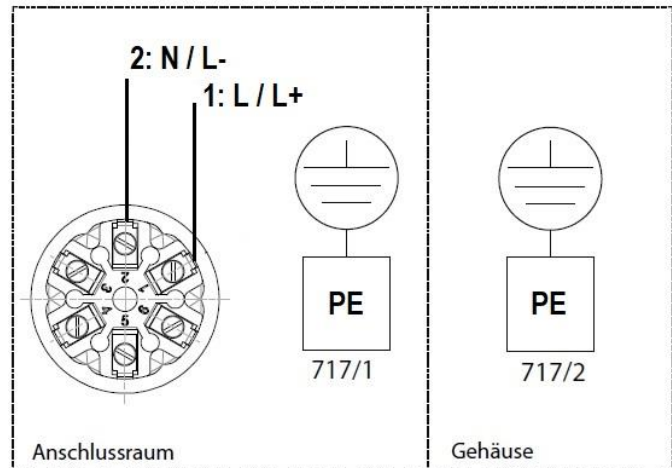

## Protective conductor connection

The solenoid actuator must always be integrated into the equipotential bonding. A connection option is available for this purpose in the terminal compartment (717/1). Pursuant to EN IEC 60079-0, along with the internal protective conductor terminal, an additional external earthing terminal is to be provided.



### NOTE!

The solenoid actuator is to be **additionally** earthed via the external earthing connection (712/2).

## Connection cross-section

|                          |   |
|--------------------------|---|
| Terminals 1/2:           | 0.75...6 mm <sup>2</sup>  |
| Earthing connections PE: | 0.75...4 mm <sup>2</sup> (6 mm <sup>2</sup> single-wire or with forked cable lug) |





### NOTE!

The connection cross-section of the earthing connections must **at least** correspond to that of terminals 1/2.

UNI-Geräte E. Mangelmann Elektrotechnische Fabrik GmbH  
Holtumsweg 13, 47652 Weeze, Germany, Tel. +49 2837/9134-0, Fax +49 2837/1444  
www.uni-geraete.de info@uni-geraete.de

# Solenoid actuator

Series MG...x, MG...-A...x

With  protection for use for correct purpose in  
Ex zone 1 and 21 according to 2014/34/EU (ATEX) 



## Sample calculations for the maximum cable length and the required cable cross-section

The maximum cable length results from multiplying the length factor with the selected cable cross-section.

Example:           Type: MG 012x 230 VAC  
                      Table value length factor: 1076 m/mm<sup>2</sup>  
                      Selected cable cross-section: 1.5 mm<sup>2</sup>  
                      → Maximum cable length = 1076 m/mm<sup>2</sup> x 1.5 mm<sup>2</sup> = 1614 m

Alternatively, the required cable cross-section can be determined by dividing the specified cable length by the length factor:

Example:           Type: MG 018x 110 VDC  
                      Table value length factor: 94 m/mm<sup>2</sup>  
                      Specified cable length: 200 m  
                      → Required cable cross-section = 200 m / 94 m/mm<sup>2</sup> = 2.13 mm<sup>2</sup>  
                      → Selected cable cross-section: 2.5 mm<sup>2</sup>

## Dimensions

(see dimensional drawing on page 13)

| Type<br>MG  | Weight<br>[kg] | Construction dimensions [mm] |     |     |     |     |    |    |    |     |
|-------------|----------------|------------------------------|-----|-----|-----|-----|----|----|----|-----|
|             |                | A                            | B   | B'  | ØC  | D   | E  | F  | G  | ØH  |
| 008x        | 16.5           | 84                           | 241 | 321 | 192 | 109 | 30 | 20 | 10 | M8  |
| 010(-A...x) | 18.0           | 84                           | 263 | 353 | 192 | 102 | 50 | 26 | 13 | M8  |
| 012(-A...x) | 18.7           | 84                           | 263 | 363 | 192 | 107 | 50 | 26 | 13 | M8  |
| 014(-A...x) | 22.0           | 94                           | 290 | 410 | 212 | 89  | 50 | 26 | 13 | M8  |
| 016(-A...x) | 25.1           | 94                           | 302 | 442 | 212 | 100 | 50 | 26 | 13 | M8  |
| 018(-A...x) | 40.6           | 115                          | 320 | 470 | 241 | 100 | 50 | 26 | 13 | M10 |
| 019(-A...x) | 42.9           | 115                          | 320 | 470 | 241 | 101 | 50 | 26 | 13 | M10 |

B'   Dimension for removing the solenoid actuator

D    Height difference between solenoid actuators MG...x, MG...-A...x and Standard MG.., MG..A.

---

UNI-Geräte E. Mangelmann Elektrotechnische Fabrik GmbH  
Holtumsweg 13, 47652 Weeze, Germany, Tel. +49 2837/9134-0, Fax +49 2837/1444  
www.uni-geraete.de   info@uni-geraete.de

# Solenoid actuator

Series MG...x, MG...-A...x

With  $\text{Ex}$  protection for use for correct purpose in  
Ex zone 1 and 21 according to 2014/34/EU (ATEX) **CE**



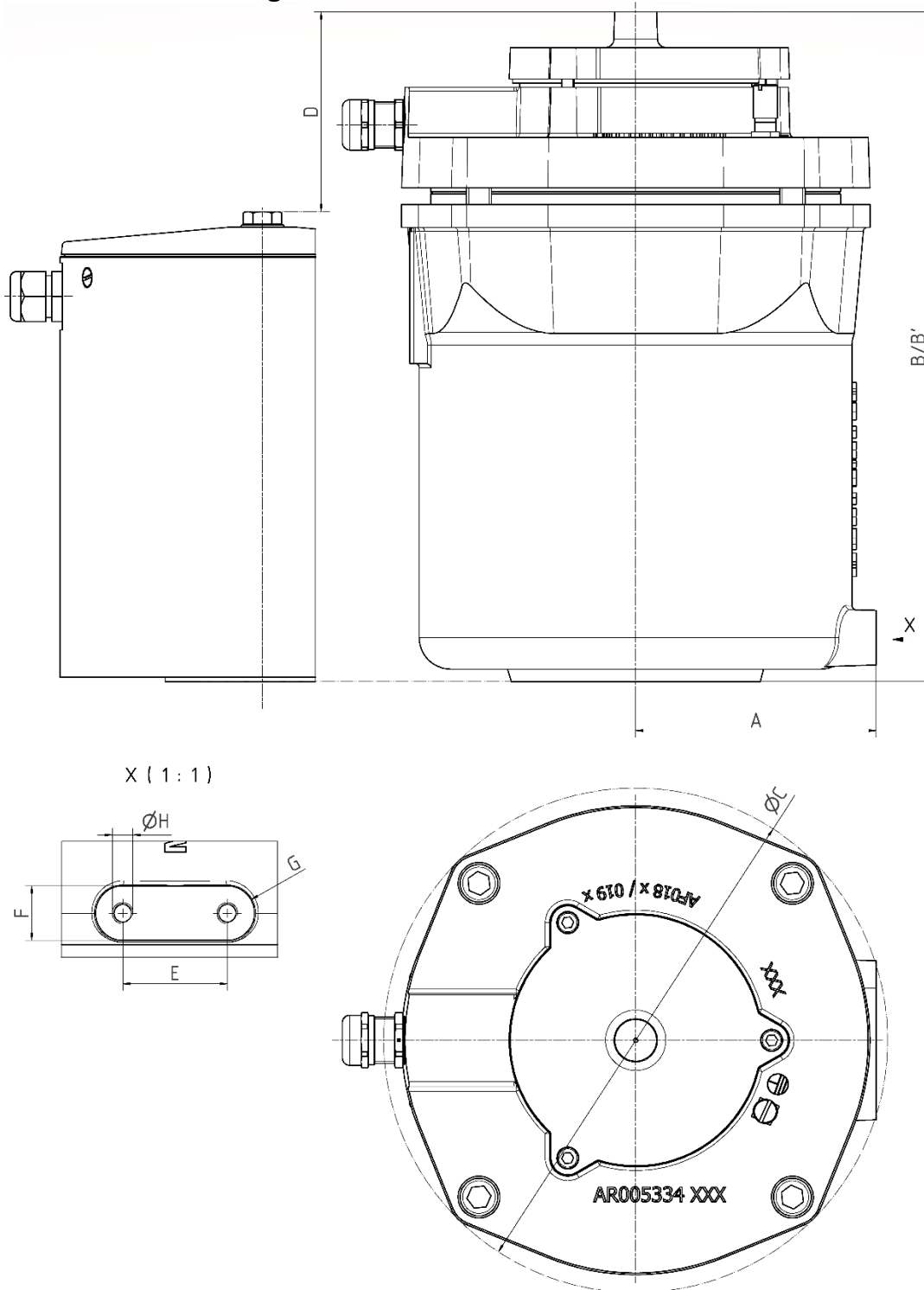

## Dimensional drawing



UNI-Geräte E. Mangelmann Elektrotechnische Fabrik GmbH  
Holtumsweg 13, 47652 Weeze, Germany, Tel. +49 2837/9134-0, Fax +49 2837/1444  
www.uni-geraete.de info@uni-geraete.de

# Solenoid actuator

Series MG...x, MG...-A...x

With  protection for use for correct purpose in  
Ex zone 1 and 21 according to 2014/34/EU (ATEX) 



## Rain protection cover

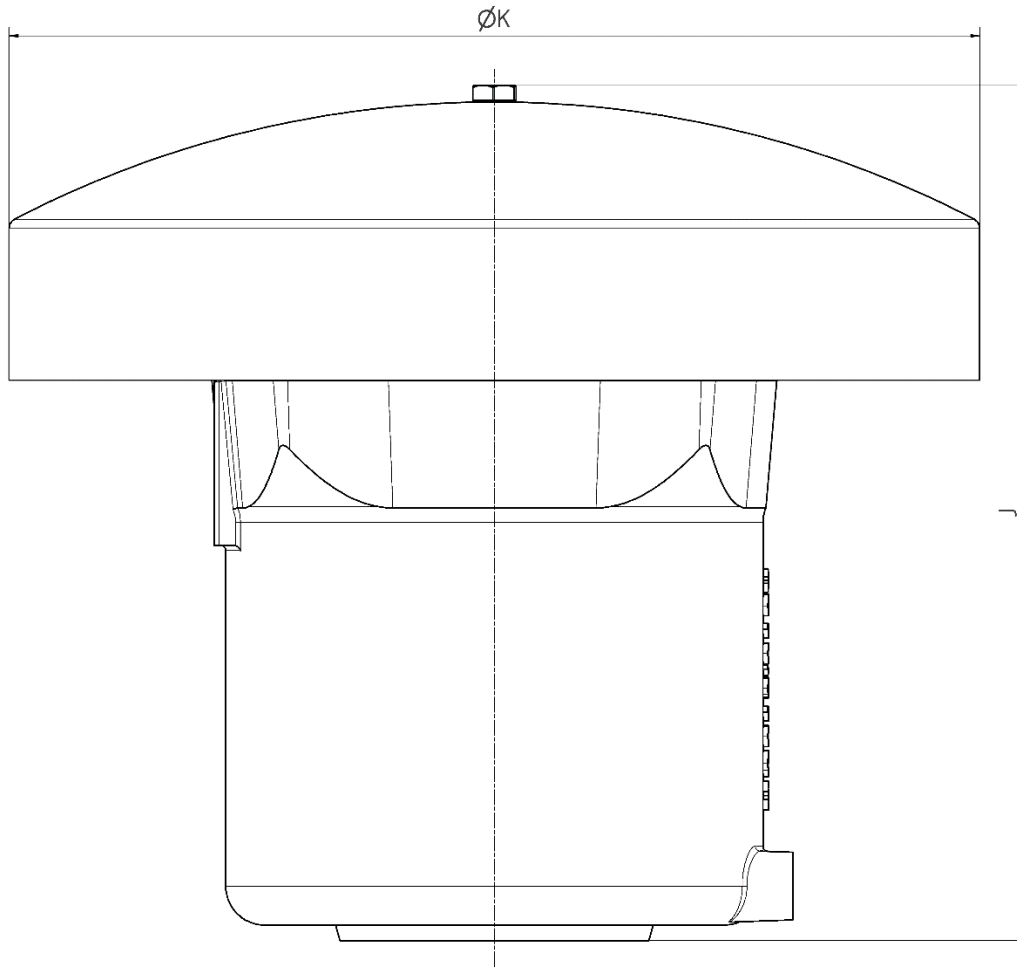



| Type<br>MG | Size | Construction<br>dimensions [mm] |     |
|------------|------|---------------------------------|-----|
|            |      | J                               | ØK  |
| 008x       | 3    | 294                             | 260 |
| 010(-A...x | 3    | 316                             | 260 |
| 012(-A...x | 3    | 316                             | 260 |
| 014(-A...x | 4    | 381                             | 370 |
| 016(-A...x | 4    | 393                             | 370 |
| 018(-A...x | 4    | 411                             | 370 |
| 019(-A...x | 4    | 411                             | 370 |

UNI-Geräte E. Mangelmann Elektrotechnische Fabrik GmbH  
Holtumsweg 13, 47652 Weeze, Germany, Tel. +49 2837/9134-0, Fax +49 2837/1444  
www.uni-geraete.de info@uni-geraete.de

# Solenoid actuator

Series MG...x, MG...-A...x

With  protection for use for correct purpose in  
Ex zone 1 and 21 according to 2014/34/EU (ATEX) 



## EU - Konformitätserklärung EU - Declaration of Conformity



**UNI-Geräte E. Mangelmann**  
**Elektrotechnische Fabrik GmbH**  
Holtumsweg 13  
47652 Weeze  
Deutschland

erklärt hiermit in alleiniger Verantwortung,  
*declares in its sole responsibility,*

für das Produkt: Elektromagnetantrieb  
*for the product: Solenoid drive*

vom Typ: MG...x, MG...-A...x  
*of type:*

das Folgende:  
*the following:*

Der oben beschriebene Gegenstand der Erklärung erfüllt die einschlägigen Harmonisierungsvorschriften der Union:  
*The object of the declaration described above complies with the relevant community harmonization legislation of the Union:*

|  |            |  |
|--|------------|--|
| EU-Richtlinien<br><i>EC-Directives</i> | 2014/34/EU | Explosionsschutzrichtlinie ATEX<br><i>ATEX directive</i> |
|  | 2014/30/EU | EMV Richtlinie<br><i>EMC directive</i>                   |

|   |   |
|---|---|
| Angewandte<br>technische Spezifikationen<br><i>Applied technical specifications</i> | EN IEC 60079-0:2018, EN 60079-1:2014+AC:2018,<br>EN 60079-7:2015/A1:2018, EN 60079-31:2014,<br>EN 161:2011+A3:2013, EN 13611:2019+AC:2021 |
|---|---|

|   |                    |
|---|--------------------|
| EG-Baumusterprüfbescheinigung<br><i>EC-Type Examination Certificate</i> | PTB 08 ATEX 1020 X |
|---|--------------------|

|                                 |  |
|---------------------------------|--|
| Kennzeichnung<br><i>Marking</i> |  II2G Ex db eb IIC T5 Gb  102<br> II2D Ex tb IIIC T95°C Db |
|---------------------------------|--|

Weeze, 31.07.2023

  
\_\_\_\_\_  
Norbert Schneider  
Geschäftsführer  
*Managing director*

  
\_\_\_\_\_  
Ralf Verrieth  
Explosionsschutzbeauftragter  
*Commisary of explosion protection*

250.000.083-10

UNI-Geräte E. Mangelmann Elektrotechnische Fabrik GmbH  
Holtumsweg 13, 47652 Weeze, Germany, Tel. +49 2837/9134-0, Fax +49 2837/1444  
www.uni-geraete.de info@uni-geraete.de